

# SP-31

## FIS GAS SENSOR SP-31

### for SOLVENTS DETECTION (ALCOHOL, SOLVENTS)

The SP-31 is a tin di-oxide semiconductor gas sensor which has a high sensitivity to solvents such as alcohol, toluene .

#### Structure

Gas sensitive semiconductor material is formed on the alumina substrate on which the gold electrodes are printed. A thick film heater of ruthenium oxide is printed on the reverse of the substrate and placed in the plastic housing (Fig 1).

#### Operating conditions

The circuit for the sensor is composed of two parts as shown in Fig 2. One part is for supplying heater voltage ( $V_H$ ) and the other is for the output signal ( $V_C$ ), which is current or voltage reflecting sensor resistance ( $R_S$ ) change. The change of the sensor resistance is generally obtained as the change of the output voltage across the fixed or variable resistor ( $R_L$ ) in series with the sensor resistance. In order to obtain the best performance and specified characteristics, the values of the heater voltage, circuit voltage and load resistance ( $R_L$ ) must be within the range of values given in the standard operating conditions shown in the Specification table on the next page.

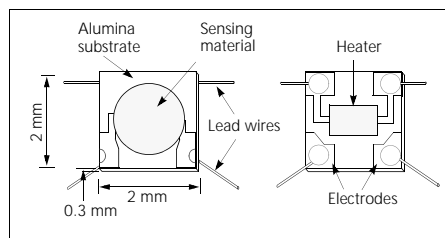

Fig 1a. Sensing element

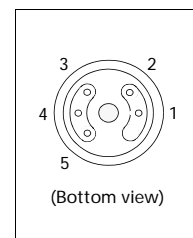

Fig 1c. Pin Layout

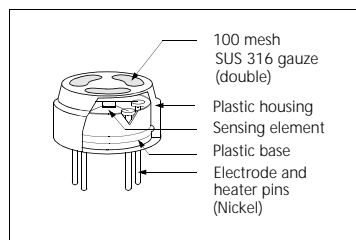

Fig 1b. Configuration

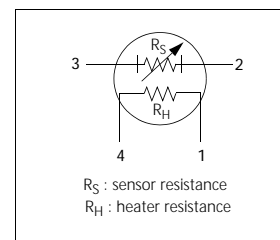

Fig 1d. Equivalent circuit

#### Sensitivity characteristics

Fig 3 shows the sensitivity characteristics curves of the SP-31 (typical data). Sensitivity characteristics of the FIS gas sensors are expressed by the relationship between the sensor resistance and gas concentration. The sensor resistance decreases with an increase of gas concentration based on a logarithmic function.

The sensitivity characteristics of the SP-31 are specified by the following parameters.

- Sensor resistance level: at ethanol 300 ppm
- Sensor resistance change ratio: between ethanol 50 ppm and 300 ppm

See the specification table on the next page for further details.

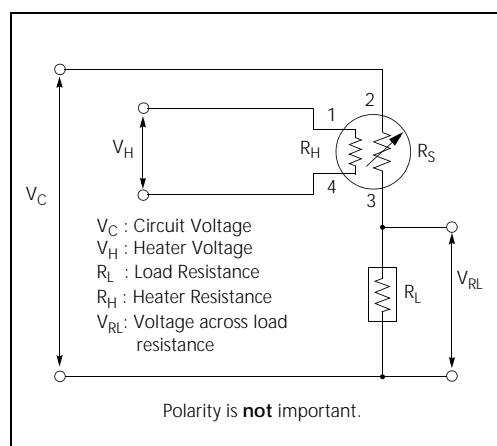

Fig 2. Standard circuit

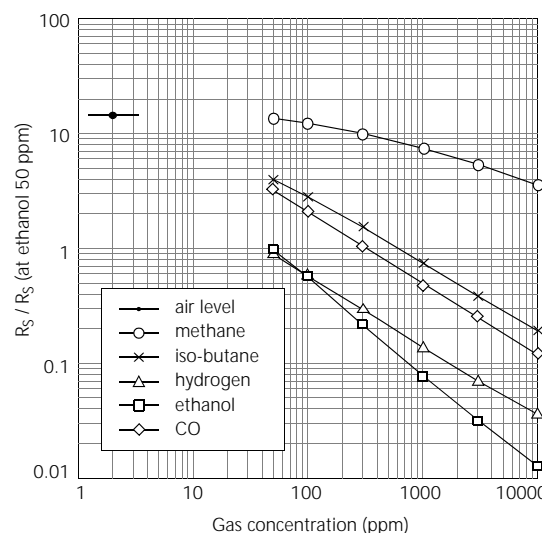

Fig 3. Sensitivity characteristics

#### SPECIFICATIONS

