

## Model T80 Universal Transmitter



Measure pH, ORP, Specific Ion, Dissolved Oxygen,  
Turbidity, Conductivity or Resistivity with  
**Model S80 Intelligent Sensors**



# Model T80 Universal Transmitter

## The ECD **6** Point Advantage

- 1 Universal Transmitter:** single or dual channel, measures pH, ORP, DO, Specific Ion, Turbidity, Conductivity or Resistivity
- 2 Graphic LCD Display:** Easy to Read Graphical and Numerical Information
- 3 Simple Menu Structure:** Intuitive, Easy to navigate and Configure
- 4 Use with ECD Digital Intelligent Sensors** that are factory calibrated sensors and store data
- 5 4-20 mA output with MODBUS RTU and Alarm Relays:** Flexible configurations for all applications
- 6 HART® communication**

## Description

The ECD Model T80 Universal Transmitter is a single or dual channel transmitter designed for the continuous measurement of pH, ORP, pION, Dissolved Oxygen, Turbidity, Conductivity or Resistivity in a general purpose industrial environment. The Model T80 transmitter digitally communicates with any ECD Model S80 Intelligent Sensor, automatically configuring the transmitter's menus and display screens to the measured parameter. The same transmitter can be used for any of the measurements, i.e. plug an S80 Conductivity Sensor into a Model T80 pH transmitter and it will automatically reconfigure into a conductivity transmitter. There is no longer any need to inventory multiple instrument types, the one Model T80 transmitter will automatically configure to any of the listed measurements.

### SENSORS

The Model S80 Intelligent Sensors facilitate two way communication with the Model T80 transmitters. The type of sensor, identity and serial number are stored in the sensor's memory along with calibration registers. The Model S80 sensors are calibrated at the factory so they are ready to use when connected to a Model T80 transmitter. The Model S80 sensors are waterproof and submersible with all internal components epoxy encapsulated inside the ¾" O.D. housing. The Model S80 sensors use the same field proven, easily replaceable electrodes as the Model S10 and S17 sensors saving time and money. A digital converter option is available for the Model T80 transmitter to allow the use of non-digital sensors. The digital converter is only available on line powered instruments.

### DISPLAY

The Model T80 Transmitter features a large easily viewed LCD display. Loop powered instruments have Black lettering on a Grey background, while 100-240 VAC and 24 VDC powered instruments have Blue lettering on a White background when the LED backlight is on. The Model T80 display is easily switched between the single and dual channel display modes. It has th e



## Model T80 Universal Transmitter

Main Display screens; the Data Screen, the Millivolt Screen and the Graphical Display screen. The Data Screen displays the measurement type, the measured value with units, the % milliamp output of the 4-20 mA channel and the temperature. The mV Screen displays the measurement type, the raw millivolt signal from the sensor, the % milliamp output of the 4-20 mA channel and the temperature. The Graphical Screens display the measurement type, the measured value with units and a graphical representation of the % milliamp output. Three graphical styles are available; a Trend line, a Bar graph or a Gauge. The status of alarm relays, energized/de-energized is displayed on transmitters with relays.

### MENUS

Menu navigation is accomplished using membrane switch buttons. Soft keys display the function associated with each button. Pressing any of the buttons twice within 2 seconds activates the Model T80 soft key menus. The primary selections are the Calibration menu, Configuration menu, Info Screens and Simulate menu.

### CALIBRATION

Model S80 sensors come precalibrated from the factory. Field calibrations are easily performed with the Model T80. The Calibration menu includes the Auto Cal function, a two point calibration, the Standardize function, a single point calibration or the Manual Calibration, where previously determined Offset and Slope values are entered manually into the Model T80 transmitter.

### CONFIGURATION

The Configuration menus allow the Model T80 transmitter's Display and Output functions and the Model S80 sensor's characteristics to be configured or adjusted. Display screens include the Hold function, Graphical Display Style, Back Light and Contrast adjustments, Labels/Tags for naming the transmitter, Password Protection and a Factory Default reset. Output screens include setting the addresses for MODBUS or HART® outputs, setting the 4-20 mA Range and fault settings and configuring the Alarm Relays.

### INFO

The Info screens provide Transmitter and Sensor Information. The transmitter screens display the Name, Power, Serial#, Firmware version and the output configuration. The sensor screens display the Name, Part #, Serial # and stored Calibration data.

### SIMULATE

The Simulate Menu allows the input and output signals to be simulated. The outputs are easily tested by entering a 4-20 mA output value or energizing and de-energizing a relay. The Ramp function cycles the signal across the configured 4-20 mA range, i.e. the transmitter generates a signal from 0 pH to 14 pH and back to 0 pH activating relays and generating a 4-20 mA output. The cycle time and the duration are adjustable allowing sufficient time for an individual to walk to the control room to verify the output.

### POWER SUPPLY and OUTPUTS

The Model T80 transmitter is available as a loop powered (single channel only), a 24 VDC or a 100/240 VAC powered transmitter. The loop powered version is available with an optional HART® output. The line powered instruments have one 4-20 mA output per channel and MODBUS RTU. Available options include HART® communication and an Alarm Relay package. The (3) relays can be configured as Alarm (set point) relays, timer activated relays or Fault relays.

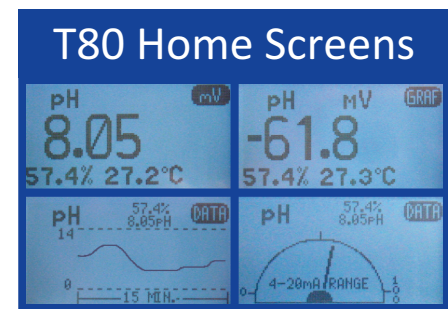

**HART**  
COMMUNICATION PROTOCOL





# Specifications

## Input Specification

Digital protocol, all ECD S80 sensors, Liquid, Gas, Process sensors (Optional analog to digital input board for mV sensors)

## Input Ranges

pH -1.00 – 15.00 pH  
 ORP -1500 - +1500 mV  
 pION 000.1 – 999.9, Auto Ranging: ppb ↔ ppm ↔ ppthousand  
 Dissolved Oxygen 000.1 – 999.9 Auto Ranging: ppb, ppm, % SAT, mg/L  
 Conductivity 0.055 μS – 2.00S Auto Ranging: μS, mS, S  
 Resistivity 0.001 - 20.00 meg-ohms  
 Turbidity 000.0 - 4000NTU Auto Ranging: NTU, FNU, mg/L, ppm, % Solids  
 Temperature -30°C - 140°C

## Accuracy

pH 0.02 pH  
 ORP ± 1 mV  
 pION Specific for ion type  
 Dissolved Oxygen 2% of calibrated range  
 Conductivity 2% of calibrated range  
 Resistivity 2% of calibrated range  
 Turbidity 4% of calibrated range  
 Temperature ± 0.3°C

## Enclosure

Polycarbonate, NEMA 4X, weatherproof, ½ DIN, (L x W x D) 5.7" X 5.7" X 3.5" (14.4cm X 14.4cm X 9.0cm)

## Environmental Conditions

Ambient Temperature -20°C - 70°C  
 Storage Temperature -30°C - 85°C  
 Relative Humidity 0 – 90% NC

## Display

128 x 64 pixels (2.75" x 1.5") LCD, Black/Grey background on loop powered instruments, Blue/White background LED backlight on 100-240 VAC and 24 VDC

powered instruments

## Input Power

Code -0 Loop powered, 24 VDC, 600 Ω maximum load (18-36VDC @ 35 mW minimum)  
 Code -1 24 VDC (18-36 VDC @ 250 mW minimum)  
 Code -2 100-240 VAC, 50/60 Hz, 4W

## Outputs

**4-20 mA output** (standard), Fault Condition: 3.5 mA, 22 mA or none  
**Modbus RTU** (standard)  
**HART®** (optional)  
**Alarm Relays** (Optional) Three (3) SPDT, form 1C, 250 VAC, 3 Amp resistive maximum relays, user configurable as Hi/Lo or Fault alarms

## Shipping

Size 8" x 8" x 5" (20.5 x 20.5 x 12.7 cm)  
 Weight 1.6 lbs. (0.75 kg)

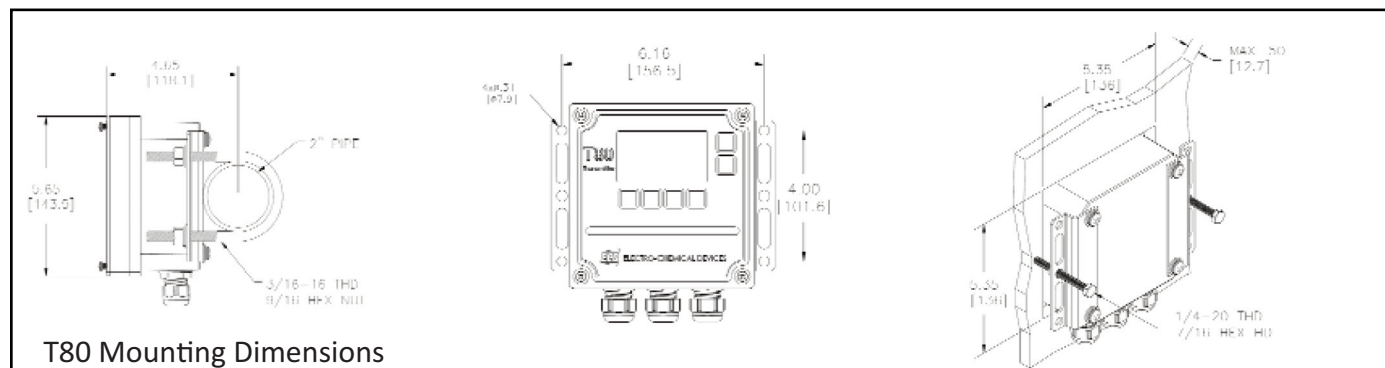

T80 Mounting Dimensions

Model T80- Transmitter Part Number Guide						
Ch 1 Inputs	1	S80 Sensor, pH, ORP, pION, Conductivity, Resistivity and galvanic Dissolved Oxygen, TRITON® DO82 Optical DO & TR86 Turbidity				
	Ch 2 Inputs	0	No Input for Channel 2			
		1	S80 Sensor, pH, ORP, pION, Conductivity, Resistivity and galvanic Dissolved Oxygen, DO82 & TR86 Turbidity			
	Power Supply	-0	Loop Powered Transmitter (not available for DO82 or TR86 sensors)			
		-1	24 VDC Powered Transmitter			
		-2	100/240 VAC, 50/60Hz, 4W powered Transmitter			
	Alarm Relays	0	No Relays			
		1	(3) formC 250 V 3A relays			
	Output	0	4-20 mA output and MODBUS RTU			
		1	HART®			
2		2 x 4-20 mA with MODBUS RTU				
Mounting Hardware		-00	No Mounting Hardware			
		-01	Universal Mount			
	-02	Panel Mount				
Model T80-	1	1	-0	0	1	-01