

ELECTROMAGNETIC FLOWMETER EFM-115

- Continuous measurement of current flow, positive and negative flow
- DN 15 – 200 mm flanged type
- Robust and resistant cover of sensor and transmitter
- Easy change from compact to remote version
- Flow direction indication
- Universal power supply



The Electromagnetic flowmeter EFM-115 is precise measuring device intended for the measurement of liquid flow of electrically conductive media. The meters may be used for measurements, registration, dosing, mixing, etc. The measurement is based on the principle of Lorentz law. In compliance with this law, electric voltage is induced in an electrically conductive body, which moves across a magnetic field.

DIMENSIONS DRAWINGS

CONTROL UNIT

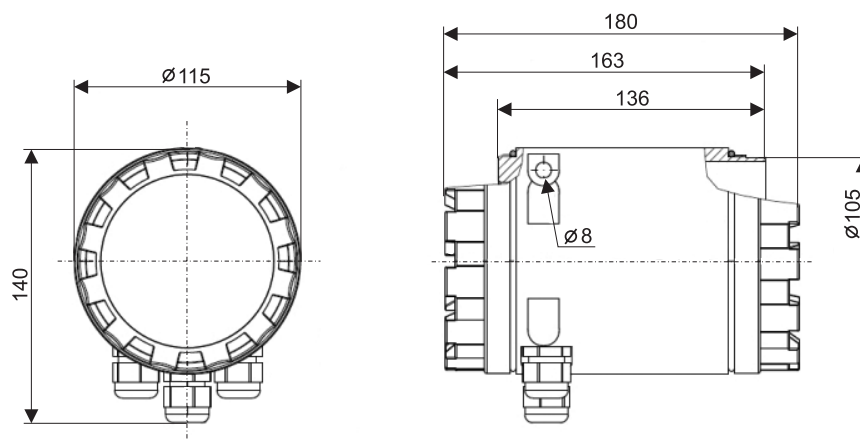

SENSOR

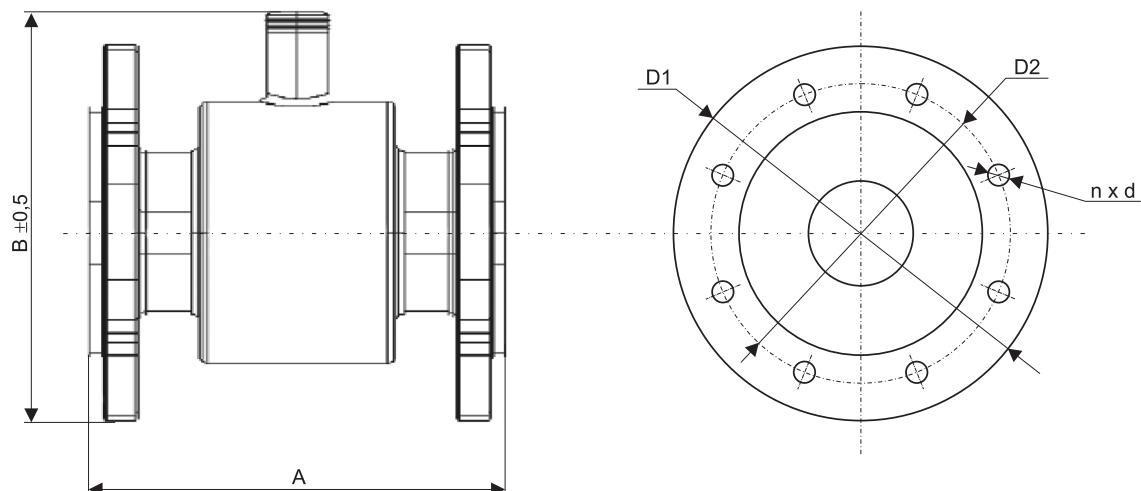

TABLE FOR 1 m/s FLOWRATES			
DN	m ³ /h	l/min	l/s
15	0,637	10,62	0,177
20	1,131	18,85	0,314
25	1,767	29,452	0,491
32	2,895	48,255	0,804
40	4,524	75,398	1,257
50	7,069	117,81	1,964
65	11,946	199,10	3,318
80	18,096	301,59	5,027
100	28,274	471,23	7,854
125	44,179	736,31	12,272
150	63,617	1060,3	17,671
200	113,10	1885,0	31,420

CONSTRUCTIONAL DIMENSIONS AND WEIGHTS OF FLOWMETERS								
DN	PN	Dimensions [mm]						Weight [kg]
		A	B	D1	D2	d	n	
15	16	150	155	95	65	14	4	2,5
20	16	150	160	105	75	14	4	3,0
25	16	150	167	115	85	14	4	3,5
32	16	150	180	140	100	18	4	5,0
40	16	150	185	150	110	18	4	6,0
50	16	200	191	165	125	18	4	7,0
65	16	200	209	185	145	18	4	8,0
80	16	200	224	200	160	18	8	9,5
100	16	250	245	220	180	18	8	12
125	16	250	276	250	210	18	8	15
150	16	300	305	285	240	22	8	20
200	16	350	375	340	295	22	12	36

TECHNICAL DATA – SENSOR	
Nominal size	DN 15 ... 200 mm
Flange type	DIN 2576–PN–16
Connecting cable	Standard 0.5 m / 2 x 2 x 0.25 mm ²
Coils excitation	Pulse DC
Isolation class of coils excitation	E
Process connection	Flanged DIN
Maximum Pressure	1.6 MPa
Protection class	IP67
Liner material / Temperature	Hard rubber / - 5°C ... +90°C
Electrodes material	Stainless steel 316Ti
Outer casing flanges / Flow tube material	Carbon steel standard / Stainless steel 321
External coating	Acrymetal multi component lacquer
Ambient temperature range	-20°C ... +50°C

TECHNICAL DATA – CONTROL UNIT	
Medium electrical conductivity	> 5 µS/cm, for demineralized water > 20 µS/cm
Electrode impedance input	≥ 10 ¹⁰ Ω
Flowrate	Min. 0.3 m/s; max. 12 m/s
Measurement accuracy	0.3 % of reading, while flow is within 10 ... 100% of range
Flow filter	Multi-mode adjustment
Low flow rejection	Adjustable in steps of 0.1 %
Flow direction	Bi-directional measurement is distinguished by sign
Zero flow	Automatic zero point setting
Data logger	4 months capacity (average 5 min. current flowrates)
Display / Resolution	Alphanumeric OLED / 2 x 16 characters, with backlight
Analog output – Active galvanically separated	4(0) ... 20 mA / 500 Ω
Frequency output – Passive galvanically separated	0 ... 1 kHz / 0 ... 100 % from flow rate range; 8.2 ... 10 kΩ Max 24 V DC
Binary outputs	1 ... 4x relays, non-voltage contact, non-inductive load 250V AC (30V DC)/3A
Communication outputs	RS–485 / Modbus RTU, galvanically separated
Cable outlets	3x PG 11, Power supply cable Max. 3x 1.5 mm ²
Power supply	85 ... 260 V AC / 50 ... 60 Hz; 9 ... 36 V DC
Power consumption	10 VA
Fuse (internal)	630 mA
Protection class	IP 67
Ambient temperature range	-20° C ... +50°C
Weight	2.6 kg
Housing material	Aluminium alloy
External coating	Powder coating

INPUT AND OUTPUT CONNECTION

	TERMINAL	DESIGN	
		Standard	Optional
SENSOR	1	Yellow	Driving
	2	Green	Driving
	3	Braiding	Ground and Shielding
	4	E2 Brown	Signal
	5	Braiding	Shielding
	6	E1 White	Signal
COMMUNICATION	7		RS-485 (Modbus RTU)
	8		A
	9		B Not connected (Cable max. 500 m)
OUTPUT	10	Analog output (active)	
	11		
	12	Not connected	
	13	Not connected	
	14	Frequency output 0 ... 1 kHz (passive)	
15			
SUPPLY	16	85 ... 260 V AC	9 ... 36 V DC
	17	Not connected	Not connected
	L	Not connected	Not connected
	N	L	+ 9 ... 36 V
	PE	N	0 V
		PE	PE
RELAY	21 22	Relay 1 – 250 V AC; <30 V DC / <3 A	Relay 2 – 250 V AC; <30 V DC / <3 A Relay 3 – 250 V AC; <30 V DC / <3 A Relay 4 – 250 V AC; <30 V DC / <3 A
	31 32		
	41 42		
	51 52		

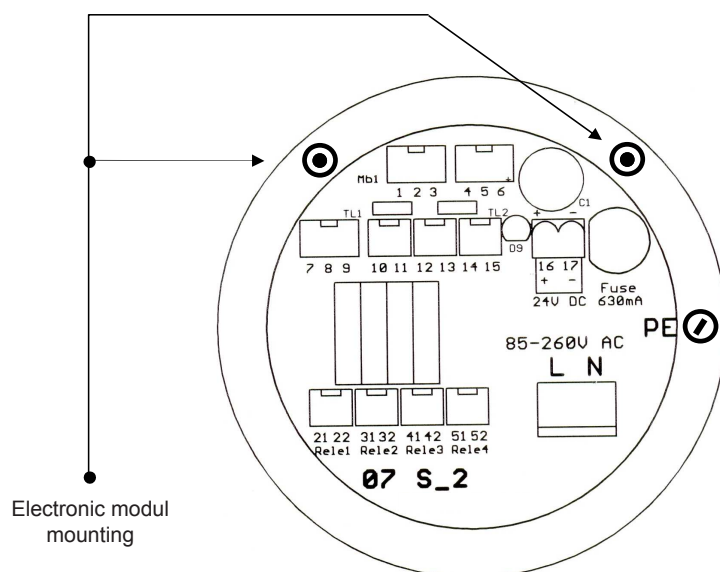

APPLICATION AND INSTALLATION

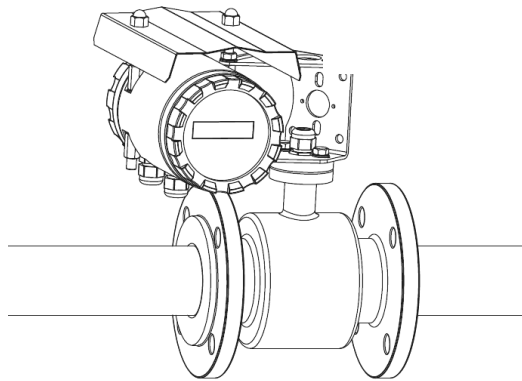

Mounting flowmeter in horizontal pipe

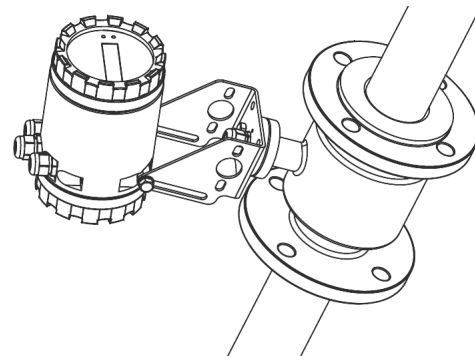

Mounting flowmeter in upward pipe

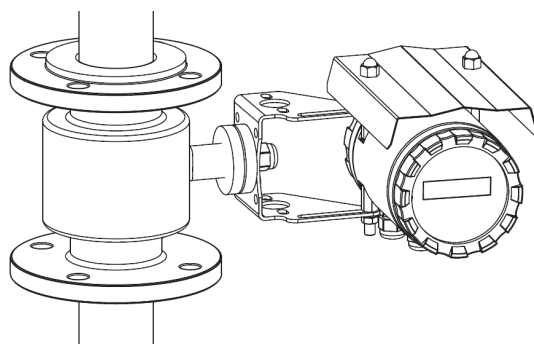

Mounting flowmeter in vertical pipe

ORDER CODE

EFM-115-DN -R - - V

Nominal size:
 15; 20; 25; 32; 40; 50;
 65; 80; 100; 125; 150; 200

Supply voltage: **230** – 85...260 VAC/50 ... 60 Hz
24 – 9...36 VDC
 Supply voltage: **0** – without communication
M – RS 485 / Modbus RTU
 Binary output: **1** – 1 Relay (250V AC; 30V DC/3A)
2 – 2 Relay (250V AC; 30V DC/3A)
3 – 3 Relay (250V AC; 30V DC/3A)

CORRECT SPECIFICATION EXAMPLES

EFM-115-DN40-R3-0-230V

(DN40) Nominal size 40 mm; (R3) Binary output 3 pcs of relay; (0) standard version without communication; (230) Supply voltage 85...260 VAC

EFM-115-DN125-R1-M-24V

(DN115) Nominal size 125 mm; (R1) Binary output 1 pcs of relay; (M) communication RS 485 / Modbus RTU; (24) Supply voltage 9 ... 36 V DC

SAFETY, PROTECTIONS AND COMPATIBILITY

Electrical safety according to EN 61010-1.

Electromagnetic compatibility is provided by conformity with standards EN 61326-1 and EN 61000-4-2, -3, -4, -5, -6, -8, -11.