

Model FS5001B

MEMS Mass Flow Sensors

VA.1



MEMS Mass Flow Sensors

Model FS5001B

Features

- Low mass flow range from 0 ~ 200 sccm up to 0 ~ 1000 sccm
- Outstanding accuracy of $\pm 2.0\%$
- Response time < 10 ms
- Pressure rating up to 5 bar (73 psi)
- Output: analog or both analog and digital

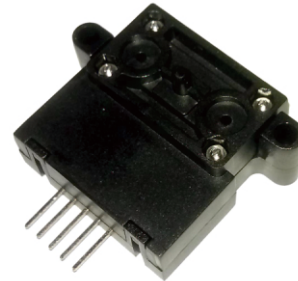

Description

The FS5001B mass flow sensors are manufactured using Siargo's proprietary MEMS flow sensor and package technology. The sensors are specially designed for low flow rate range applications from 0 ~ 200 sccm to 0 ~ 1000 sccm. The maximum flow rate for each model is manufactured via specially designed package as well as smart electronics so that the optimal sensitivity would be achieved.

The packaging enclosure is made of the chemically inert and thermally stable polycarbonate material. The maximum over pressure rating can reach up to 5 bar (73 psi) that is benefitted from Siargo's unique MEMS sensor chip structure, special packaging technology and the rugged sensor housing.

The FS5001B can be used in a wide range of applications including mass flow metering for process control, gas flow metrology, heating ventilation and air conditioning solutions as well as medical applications. The FS5001B requires a power supply of 8 ~ 24 Vdc and provides an analog output or both analog and digital outputs. The analog output is linearized from 0.5 to 4.5 Vdc corresponding with flow rate from 0 to full scale. The digital output is I²C. The I²C protocol can be obtained from the manufacturer.

The calibration is generally performed with air at 20 °C and 101.325 kPa pressure rating. It can nonetheless be calibrated with other gases and conditions upon requests.

Working Principle

The MEMS sensor chip utilizes the calorimetric principle. It is packaged on a plate installed inside the flow channel, which provides additional flow conditioning from the boundary layer configuration resulting in a laminar flow. The mass flow measurement is established as the gas carries heat away from the heater leading to the redistribution of the temperature field. Accurate flow rate is obtained by calibration with standard gas at preset conditions.

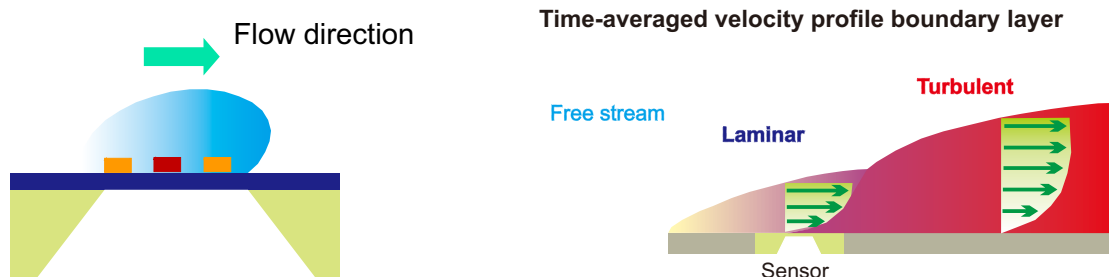

MEMS Mass Flow Sensors

Block Diagram

The functional block diagram is shown in the following figure. The MEMS sensor chip is powered by the sensor driving circuitry and sends flow rate related voltage to ADC. The micro-controller processes

(amplifying, filtering, etc) the voltage then converts into flow rate. The flow rate signal is sent out through analog or both analog and digital formats (I^2C).

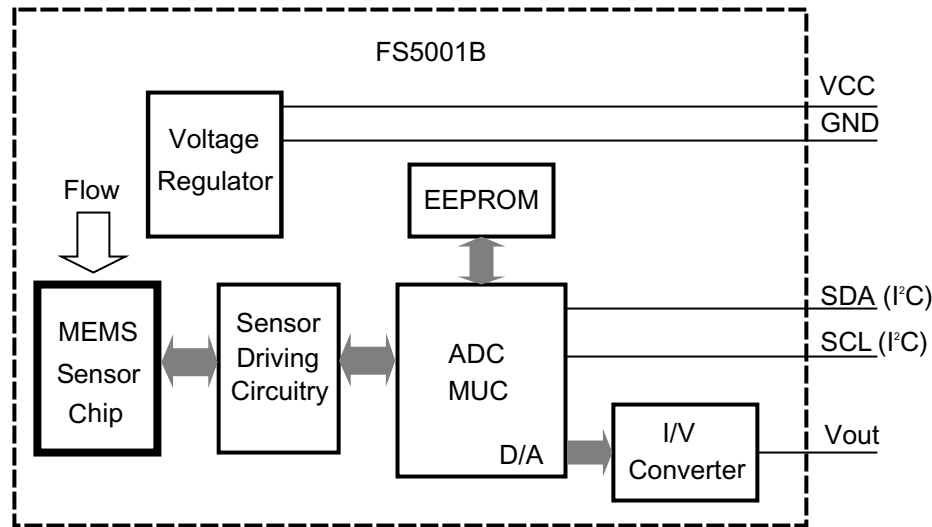

Functional block diagram of the FS5001B.

MEMS Mass Flow Sensors

1. Sensor Performance

1.1 Performance Specifications

All data unless otherwise noted apply for calibration conditions: N₂, 20°C, 101.325kPa absolute pressure, horizontal mounting.

Model	FS5001B	
Flow Range	0 ~ 200, 500, 1000 sccm	0 ~ 6 SLPM
Turn-down Ratio	100:1	
Accuracy ¹	±(2.0 ± 0.5FS)	%
Repeatability	± 0.5	%Reading
Null Shift	± 30	mV
Output Shift	± 0.12	%/°C
Response Time ²	10 (Default, 5, 10, 20, 50, 100, 200, 500, 1000 selectable)	
Output	Linear: I ² C, Analog 0.5 ~ 4.5 Vdc	
Pressure Drop ³	< 900	Pa
Working Pressure	-0.08 ~ +0.5	MPa
Power Supply ⁴	8 ~ 24 Vdc, 50 mA	
Operating Current	20 mA	mA
Power Consumption	<220	mW
Analog Output Load	Sourcing: 25	mA
	Sinking: 15	
Working Temperature	-5 ~ +45	°C

1 Denotes ±(2.0 %Reading + 0.5 %Full Scale). To obtain accurate flow measurement, let the sensor warm up 1 minute at power up.

2 The response time is determined by ADC sampling rate and data process algorithm. The default response time is 10 ms. It can be programmed via I²C communication.

3 The maximum pressure drop is measured at flow rate 1000 sccm. For lower range flow sensors, the pressure drop will be smaller. See section 1.4 for details.

4 One DC power supply is necessary. The required minimum output current is 50 mA. The sensor actually consumes less than that in operation.

1.2 Additional Specifications

Pins Out	5 Pin, 2.54 mm centers, 0.635 mm square	
Calibration Options	Air @ 20 °C, 101.325 kPa	
Packaging material	Polycarbonate	
Dimensions	39.6 x 36.3 x 15.7	mm ³
Weight	15	g
Storage Temperature	-20 ~ +55	°C
Humidity	<95 %RH (No icing or condensation)	

MEMS Mass Flow Sensors

1.3 Flow Characteristics

1.3.1 Analog Output Characteristics

The FS5001B provides an analog output of 0.5 ~ 4.5 Vdc corresponding with 0 ~ full scale flow rate. Using 500 sccm as an example, the typical analog output v.s. flow rate is illustrated in Table 1.1 and Figure 1.1.

Table 1.1: Typical output voltage v.s. flow rate.

Flow Rate (sccm)	Typical Voltage (Vdc)
0	0.5
100	1.3
200	2.1
300	2.9
400	3.7
500	4.5
550	4.9
600	4.9

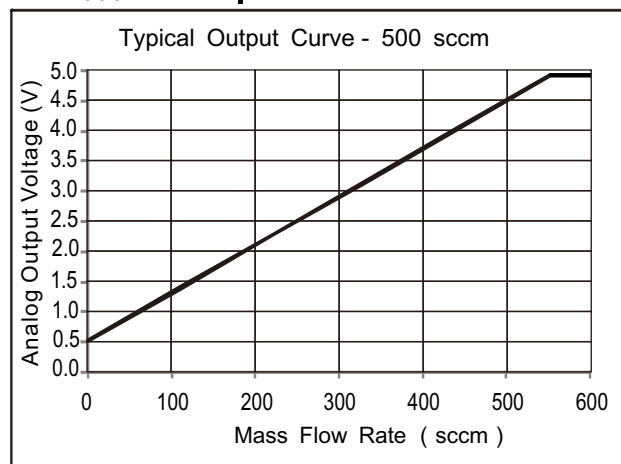

Figure 1.1: A typical analog output curve.

The sensor is calibrated 10% above the full scale flow rate to ensure the accuracy within the defined range during interpolation. For example, full scale of 500 sccm is calibrated till 550 sccm. Hence at flow rate beyond the full scale, there is still analog output but the accuracy is not guaranteed.

1.3.2 Digital Output Characteristics

The digital output is delivered through I²C. Same as analog output, when flow rate is beyond the defined full scale, the output accuracy is not guaranteed.

1.4 Pressure Drop Characteristics

The pressure drop of FS5001B is dependent on the flow rate applied, it is illustrated in Table 1.2 and Figure 1.2.

Table 1.2: Pressure drop v.s. flow rate.

Flow Rate (sccm)	Pressure Drop (Pa)
0	0
200	50
400	150
600	320
800	560
1000	850

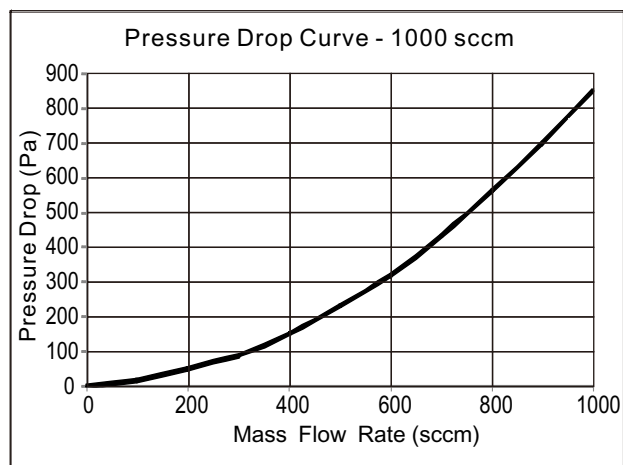

Figure 1.2: Pressure drop v.s. flow rate for sensors with the same package for full scale of 1000 sccm.

MEMS Mass Flow Sensors

2. Pins and Interface

2.1 Pin Definition

The FS5001B provides 5 pin interface. The pin layout and definition are as Figure 2.1 and Table 2.1.

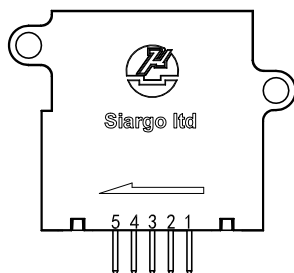

Figure 2.1: FS5001B pin configuration.

Table 2.1: FS5001B pin definition.

Pin Num.	Definition
1	SDA (I ² C)
2	Vout, Analog output
3	VCC, Power supply
4	GND, Ground
5	SCL (I ² C)

2.2 Pin Description

VCC and GND: The FS5001B requires a power supply of 8 ~ 24 Vdc. The voltage is internally regulated to power the circuitry. Therefore, there is no stringent requirements on the accuracy, stability as well as ripple of the external supply.

Vout: The analog output pin provides 0.5 ~ 4.5 Vdc corresponding with the specified flow range 0 ~ full scale. Beyond this range, there is still voltage reading, but the accuracy is not guaranteed.

SDA and SCL: For I²C, please contact Siargo for protocol.

3. Mechanical Dimensions and Mountings

3.1 Sensor Mechanical Dimensions

The FS5001B has a dimension of 39.6 x 36.3 x 15.7 mm³. The dimension is illustrated in Figure 3.1.

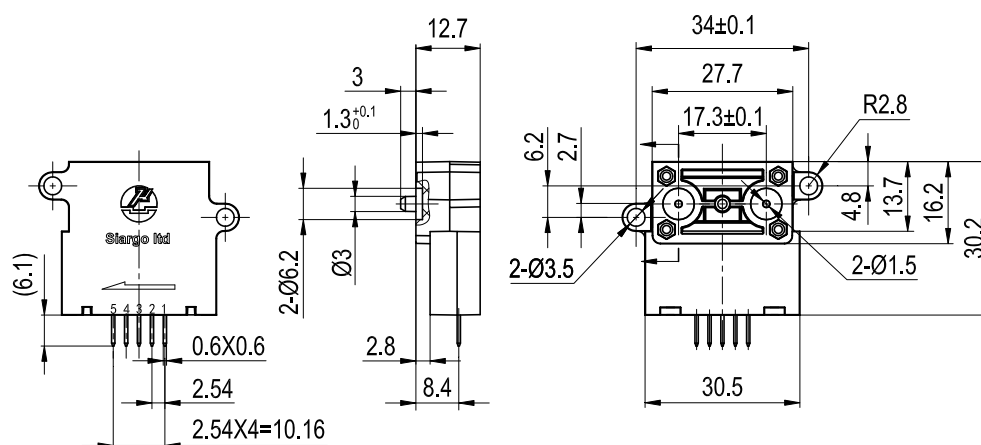

Figure 3.1: Mechanical dimensions of the FS5001B.

MEMS Mass Flow Sensors

4. Ordering Guide

4.1 Sensor Selection

The sensor part number is composed of the model number and suffix indicating the full scale flow rate, output format as well as the calibration gas. Refer to the followings for details.

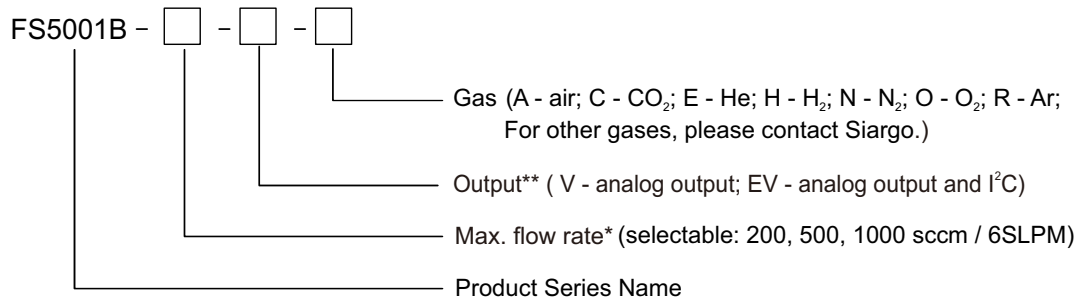

* Max. flow rate number only, for example, 500 means max. flow rate of 500 sccm, 6 means max. flow rate of 6 SLPM;
For CO₂, selectable: 200, 500, 750 sccm (without 1000sccm) or 5 SLPM (without 6SLPM);

** The sensor standard output is analog, while digital output is optional.

4.3 Order Contact and Customer Support

The sales offices are listed at the end of this document. For small quantities, the order can be placed either through Siargo website: www.siargo.com or the sales office. For large quantities, please contact the sales office or distributors or sales representatives.

Siargo is making every effort to ensure the quality of the products. In case of questions and/or product supports, please contact customer service listed at the end of the document. We will respond your request in a timely fashion and will work with you toward your complete satisfaction.

MEMS Mass Flow Sensors

Important Notices

Wetted Materials and Compatibility

The sensor body is made of medical compatible plastics. The sensor chip comprises of silicon, silicon nitride and silicon dioxide and the sensor chip surfaces are passivated with silicon nitride and silicon dioxide. The electronic sealing is provided by RTV (room temperature vulcanizing) silicone sealant WR-704 composed of $\text{HOCH}_3(\text{SiO})_n\text{CH}_3\text{H}$.

Cautions for Handling and Installations

The product at the time of shipment is fully inspected for product quality and meets all safety requirements. Additional safety measures during handling and installation should be applied. To prevent ESD (electrostatic discharge) damage and /or degradation, take customary and statutory ESD precautions when handling. Do power the product with the correct polarity, voltage and amperage. All precautions and measures for electrical voltage handling must apply. The product sealing is ensured to work under working pressure of 0.5MPa and is leakage proof before the shipment. But cautions and further leakage test are important at installation as well since any leakage may cause severe safety issues.

This product contains no user serviceable components. Do not attempt to disassemble, substitute parts or perform unauthorized modifications to the product. Doing so will forfeit the terms of the warranty and cause the liability to any damages thereafter. The product should only be serviced by authorized personnel. Upon requests, Siargo will provide necessary technical support and/or training of the personnel.

Cautions for Product Applications

The product is designed for use with general purpose gases such as air and nitrogen. It is advised that the products are best used for non-explosive clean gases. The sensors cannot be used for gas metrology of fluoride or fluoride-containing gases. For updates of the product certification information, please contact the manufacturer. Use for other gases such as extreme corrosive and toxic gases may cause the product malfunctioning or even severe damages.

Don't expose the product's outer surface to any liquids, the unit does not have a water tight electronics package.

Don't flow gas in conditions that can cause condensing water vapor to be trapped inside the unit as the accuracy could be significantly altered.

It is suggested to design your application so that nominal flow rate is approximately 70% of the full scale

flow rate of the sensor. Don't use a sensor with an extreme flow rate, for instance, don't use a 1000sccm sensor for a 10 sccm application.

Warranty and Liability

(effective March 2009)

Siargo warrants the products sold hereunder, properly used and properly installed under normal circumstances and service as described in the user manual, shall be free from faulty materials or workmanship for 180 days for OEM products, and 365 days for non-OEM products from the date of shipment. This warranty period is inclusive of any statutory warranty. Any repair or replacement serviced product shall bear the same terms in this warranty.

Siargo makes no other warranty, express or implied and assumes no liability for any special or incidental damage or charges, including but not limited to any damages or charges due to installation, dismantling, reinstallation or any other consequential or indirect damages of any kind. To the extent permitted by law, the exclusive remedy of the user or purchaser, and the limit of Siargo's liability for any and all losses, injuries or damages concerning the products including claims based on contract, negligence, tort, strictly liability or otherwise shall be the return of products to Siargo, and upon verification of Siargo to prove to be defective, at its sole option, to refund, repair or replacement of the products. No action, regardless of form, may be brought against Siargo more than 365 days after a cause of action has accrued. The products returned under warranty to Siargo shall be at user or purchaser's risk of loss, and will be returned, if at all, at Siargo's risk of loss. Purchasers or users are deemed to have accepted this limitation of warranty and liability, which contains the complete and exclusive limited warranty of Siargo, and it shall not be amended, modified or its terms waived except by Siargo's sole action. This warranty is subject to the following exclusions:

- (1) Products that have been altered, modified or have been subject to unusual physical or electrical circumstances indicated but not limited to those stated in this document or any other actions which cannot be deemed as proper use of the products;
- (2) Siargo does not provide any warranty on finished goods manufactured by others. Only the original manufacturer's warranty applies;
- (3) Products re-sold to the third parties.