

Electrochemical
Formaldehyde Sensor
(Model: ME2-CH₂O-16×15)

Manual V1.0

Valid from 2014-11-20

ME2-CH₂O-16×15 Formaldehyde Sensor

ME2-CH₂O-16×15 electrochemical sensor detect gas concentration by measuring current based on the electrochemical principle, which utilizes the electrochemical oxidation process of target gas on the working electrode inside the electrolytic cell, the current produced in electrochemical reaction of the target gas are in direct proportion with its concentration while following Faraday law, then concentration of the gas could be get by measuring value of current.

Features:

- * Low consumption
- * High precision
- * High sensitivity
- * Wide linear range
- * Good anti-interference ability
- * Excellent repeatability and stability



Application

Detecting CH₂O in residential occasion and environmental protection areas

Technical Parameter

Item	Parameter
Detection gas	Formaldehyde (CH ₂ O)
Measurement Range	0-5 ppm
Max detecting concentration	20 ppm
Sensitivity	(0.45±0.15) μA/ppm
Resolution ratio	≤0.02ppm
Response time (T ₉₀)	≤60S
Load resistance (recommended)	100Ω
Repeatability	<2% output value
Output Linearity	linear
Zero drift (-20℃~40℃)	≤0.2ppm
Humidity Range	15% ~ 90% RH
Temperature Range	-20℃ ~ 50℃
Pressure range	normal atmosphere ± 10%
Anticipated using life	2 years(in air)

External dimension

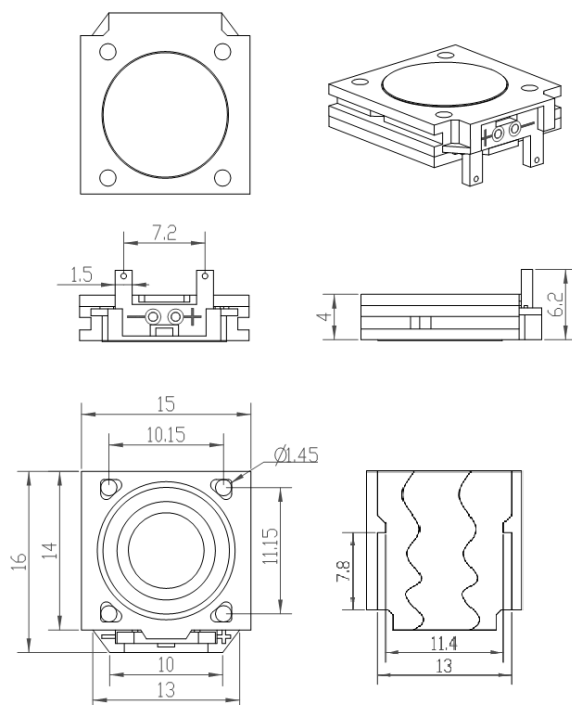

Basic circuit

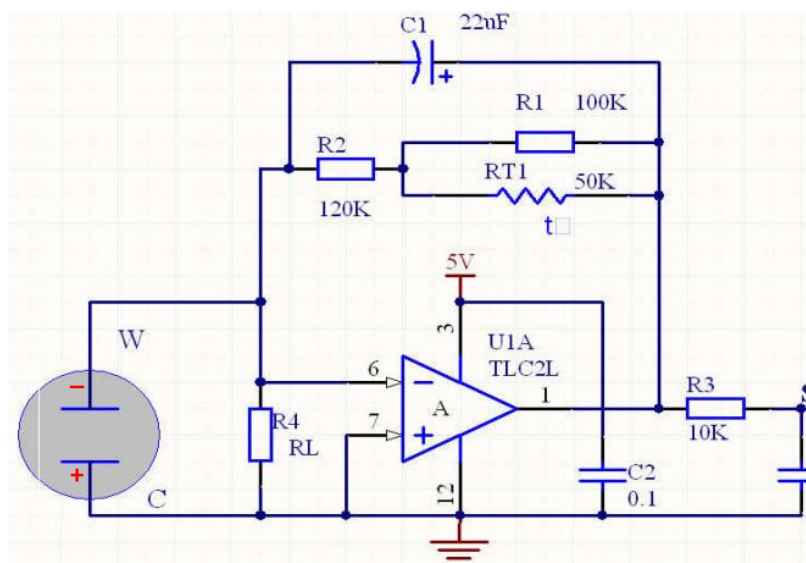

Characterization

Fig3.Features of Sensitivity, response and recovery

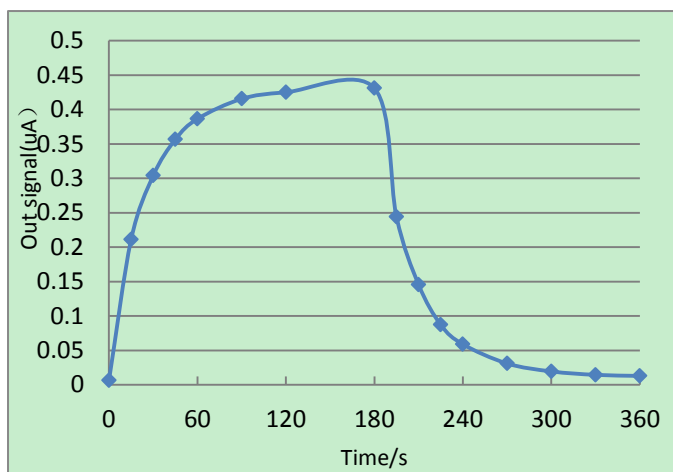

Fig5.Sensor output Change upon Variable Temperature

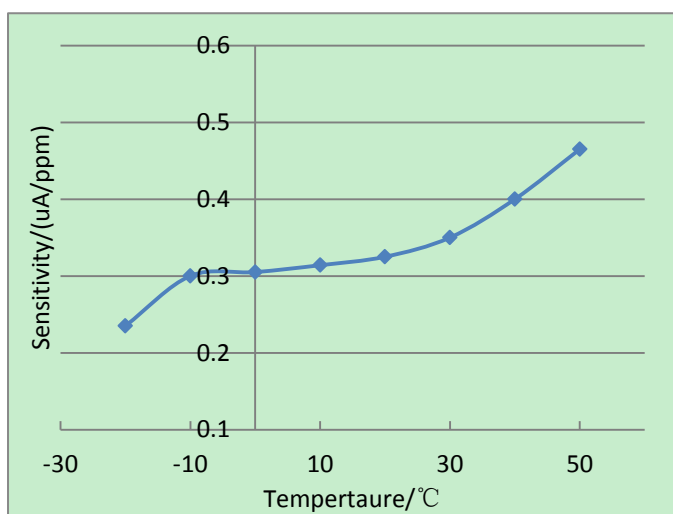

Fig4.Data graph of concentration linearity features

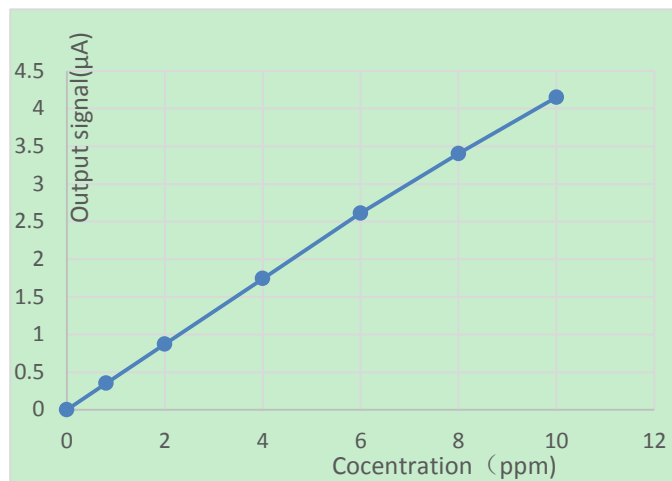
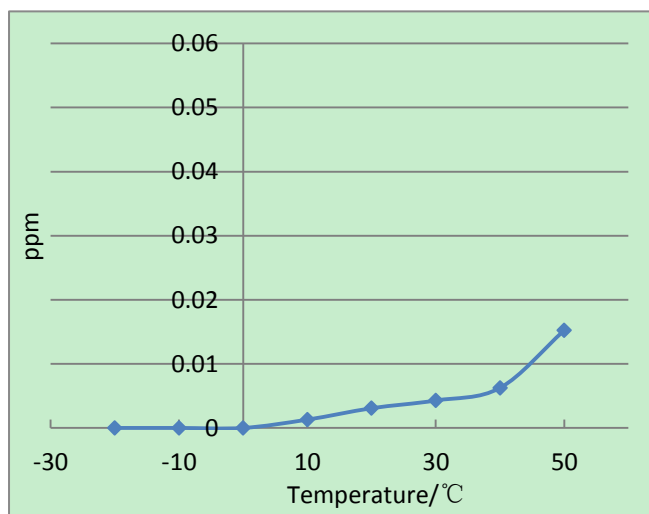

Fig6.Sensor Zero Drift upon variable temperature



There are two ways to fix the ME2-CH2O-16×15 sensor

Fix the sensor in PCB or instrument shells through fixing hole by using nut

Fix the sensor through the fixing slot

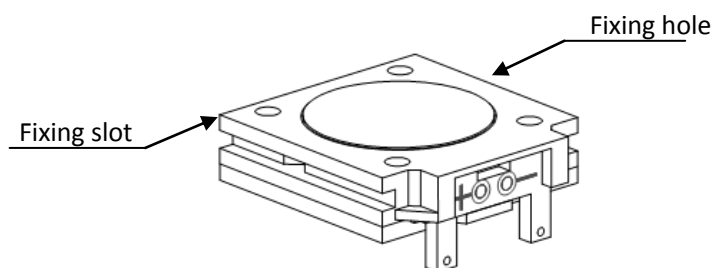

Cross interference gas

ME2-CH2O-16x15 sensor also responds to other gases besides CH2O. Below are the response characteristics of interferential gases

Gas	Concentration/ppm	Equal to HCHO
CH2O	5ppm	5ppm
C6H6	10ppm	0.1ppm
C7H8	10ppm	0.46ppm
CH3COOH	200ppm	0.52ppm
C2H5OH	100ppm	40.6ppm
H2S	50ppm	3ppm
CO	200ppm	0.64ppm

Application Notes:

- Do not break and bend the PCB terminals;
- To preheat for no less than 48hs before using;
- Do not take apart the sensor, otherwise electrolyte leakage can cause sensor damage;
- Sensor shall avoid organic solvent, coatings, medicine, oil and high concentration gases;
- All electrochemical sensors shall not be encapsulated completely by resin materials, and shall not immerse in pure oxygen environment, otherwise, it will damage the function of sensor;
- All ME sensors shall not be applied in corrosive gas environment, or the sensor will be damaged;
- Please test the zero point of gas sensors in clean atmosphere;
- Sensors shall be avoided to face the gas, which flow directly from front side;
- Blowhole of the sensor should not be blocked and polluted, which will cause the sensitivity decrease;

-
- Do not open and damage the above waterproof breathable membrane of the sensor;
 - Excessive impact or vibration should be avoided;
 - Do not use the sensor when the shell is damaged;
 - It takes some time for the sensor to return to normal state after applied in high concentration gas;
 - Working electrode and reference electrode of the sensor shall be in short circuit when stored;
 - Please do not encapsulate the sensor using melt adhesive and sealant, whose curing temperature is higher than 80 °C;
 - Please do not expose and use the sensor in high concentration alkaline gas for a long time.