

NAP-100 Series

NAP-100 series are flammable gas sensors for industrial applications, and 4 types are provided for users' choice. For detailed technical information, please refer to the individual user's manuals.

*** Ratings and gas sensitivity**

Items	NAP-100AM	NAP-100AC	NAP-100AD	NAP-100AH
Supply voltage	2.6V	2.6V	2.6V	1.6V
Current	160 ~ 180mA	160 ~ 180mA	160 ~ 180mA	120 ~ 140mA
Ambient temp. & humidity in operation	-10 ~ +50°C 95%RH or less	-10 ~ +50°C 95%RH or less	260°C or less 95%RH or less	260°C or less 95%RH or less
Ambient temp. & humidity in storage	-20 ~ +60°C 99%RH or less	-20 ~ +60°C 99%RH or less	-20 ~ +60°C 99%RH or less	-20 ~ +60°C 99%RH or less
Applications	Universal type	For higher conc.	For high temp.	For H ₂ only
Target gases	Flammable	Flammable	Flammable	H ₂ , CO
Detection range in high accuracy	1 ~ 50%LEL	3 ~ 100%LEL	1 ~ 50%LEL	1 ~ 50%LEL

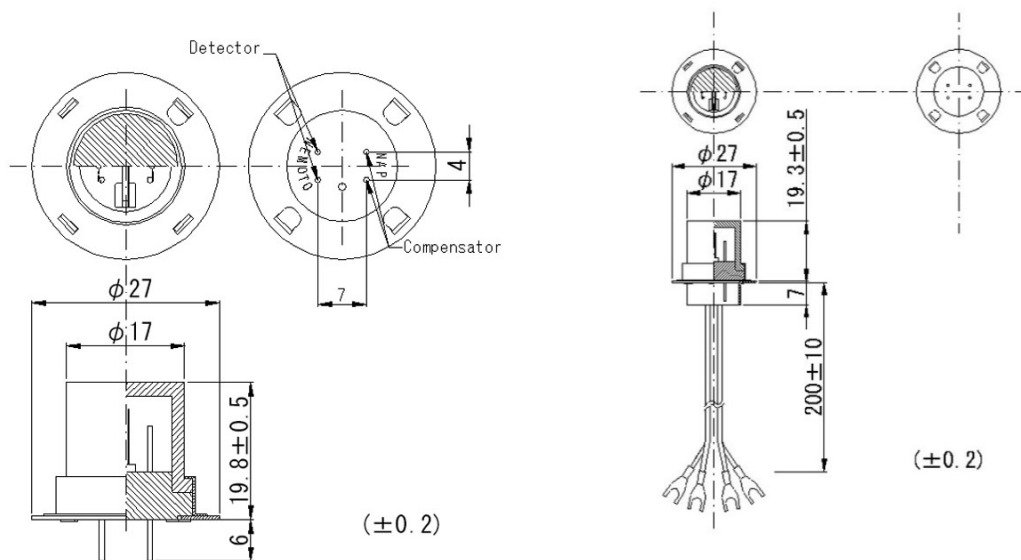

Structure of NAP-100AD and 100AH (Both are applicable)

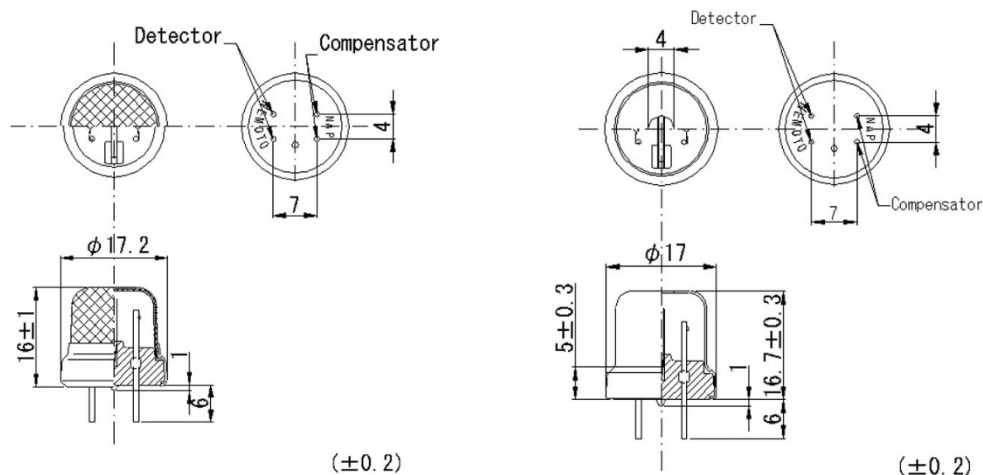

Structure of NAP-100AM

Structure of NAP-100AC