

The Classic of Touch Solution!

# GREENCHIP

---

## GreenTouch3™ GT304L Capacitive Touch Sensor

v1.2  
SPECIFICATION

## REVISION HISTORY

Version	Date	Revision Contents
v1.0	November 2014	Release version
v1.1	January 2015	Update DC Electrical Characteristic values Add QFN16 PKG Information
v1.2	June 2015	Change minimum value of 'Target supply voltage' in DC Electrical Characteristics

Copyright © 2009 by GreenChip Inc. - All Rights RESERVE.

GreenChip owns all right, title and interest in the property and products described herein, unless otherwise indicated. No part of this document may be translated to another language or produced or transmitted in any form or by any information storage and retrieval system without written permission from GreenChip.

GreenChip reserves the right to change products and specifications without written notice. Customers are advised to obtain the latest versions of any product specifications.

GREENCHIP MAKES NO WARRANTIES, EXPRESSED OR IMPLIED, OF MERCHANTABILITY OR FITNESS FOR A PARTICULAR PURPOSE, OTHER THAN COMPLIANCE WITH THE APPLICABLE GREENCHIP SPECIFICATION SHEET FOR THE PRODUCT AT THE TIME OF DELIVERY. IN NO EVENT SHALL GREENCHIP BE LIABLE FOR ANY INDIRECT, INCIDENTAL OR CONSEQUENTIAL DAMAGES AS A RESULT OF THE PRODUCT'S PERFORMANCE OR FAILURE TO MEET ANY ASPECT OF SUCH SPECIFICATION. GREENCHIP PRODUCTS ARE NOT DESIGNED OR INTENDED FOR USE IN LIFE SUPPORT APPLIANCES, DEVICES OR SYSTEMS WHERE A MALFUNCTION OF A GREENCHIP DEVICE COULD RESULT IN A PERSONAL INJURY OR LOSS OF LIFE. CUSTOMERS USING OR SELLING GREENCHIP DEVICES FOR USE IN SUCH APPLICATIONS DO SO AT THEIR OWN RISK AND AGREE TO FULLY INDEMNIFY GREENCHIP FOR ANY DAMAGES RESULTING FROM SUCH IMPROPER USE OR SALE.

Information contained herein is presented only as a guide for the applications of our products. GreenChip does not warrant this product to be free of claims of patent infringement by any third party and disclaims any warranty or indemnification against patent infringement. No responsibility is assumed by GreenChip for any patent infringement resulting from use of its products by themselves or in combination with any other products. No license is hereby granted by implication or otherwise under any patent or patent rights of GreenChip.

The GreenChip logo is a registered trademark of GreenChip.

[www.greenchip.co.kr](http://www.greenchip.co.kr)

### GENERAL

The GT304L is one of the new GreenTouch3™ capacitive touch sensor series. Especially the GT304L can do capacitance sensing with 4 channels under above GreenTouch3™ engine operation.

Thanks to this epochal GreenTouch3™ engine, the applications will be more robust and problem free against EMC, EMI, H/W variations, voltage disturbance, temperature drift, humidity drift and so on. Especially, it doesn't make any issue against CS and EFT noise environments occurred in any touch applications.

The GT304L offers 4 LED drivers with 32 steps dimming controller. The OUT[1:4] ports can be used for PWM output for LED dimming control. It's very economical solution when the LED feedbacks are required because there is no additional material cost for LED control.

For the touch output result, the I<sup>2</sup>C or 1 to 1 direct output interface can be used. I<sup>2</sup>C interface might be useful when the MCU IO or connector resource is not enough in the application.

The GT304L can be applied under wide supply voltage range from 2.5 V to 5.0V. And it has CTRL/A0 pin to select sensitivity options and I<sup>2</sup>C-bus slave address by making the pin connection to VDD and GND.

### FEATURES

- 4 channels cap. Sensing input
- **Embedded GreenTouch3™ Engine**
  - Analog compensation circuit
  - Embedded digital noise filter
  - Intelligent sensitivity calibration
  - Embedded CS, EFT enhancer core
- Two types of interface support
  - 1:1 direct Output mode.
  - I<sup>2</sup>C interface mode
- Provide interrupt function
- LED driver (32 steps dimming control)
- Sensitivity control by CTRL pin connection
- Incredibly low power consumption
  - Normal stand-by : 145uA (@3.3V)
  - Normal stand-by : 160uA (@5.0V)
- Wide supply voltage range: 2.5V to 5.0V single supply operation
- Package type
  - SOP14L
  - QFN16L
- RoHS compliant

### BLOCK DIAGRAM

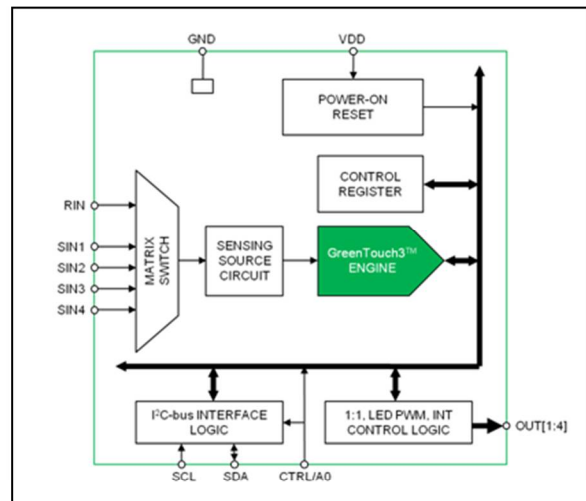

### APPLICATIONS

- Multi key application – Door lock, Remote controller and Etc.
- Portable Electronics - Mobile phone, MP3, PMP, PDA, Navigation, Digital Camera, Video Camera and Etc.
- Multimedia Devices - TV, DVD player, Blue ray player, Digital photo frame, Home theater system and Etc.
- Home Appliance - Refrigerator, Air cleaner, Air conditioner, Washing machine, Micro wave oven and Etc.
- PC, OA and Others - PC, LCD monitor Fax, Copy machine, Lighting controls, Toys, Gaming devices and Etc.

### ORDERING INFORMATION

Part No.	Package
GT304L-SO	SOP14L
GT304L-QN	QFN16L

### MARKING INFORMATION (SOP14L)

**GT304L**  
**XXXXXXX**  
**YYWW**

- GT304L : Device Code
- XXXXXXX : Lot No.
- YY : Year Code / WW : Week Code

### MARKING INFORMATION (QFN16L)

**GT304L**  
**XXXXXXX**  
**YYWW**

- GT304L : Device Code
- XXXXXXX : Lot No.
- YY : Year Code / WW : Week Code

## Table of Contents

1. Absolute Maximum Ratings.....	5
2. DC Electrical Characteristics.....	6
3. I <sup>2</sup> C-bus Characteristics.....	8
4. Pinout Information.....	9
4-1. SOP14L PACKAGE.....	9
4-2. QFN16L PACKAGE.....	10
5. Internal POWER-ON RESET.....	11
6. Touch Sensing Input Implementation (RIN, SIN).....	12
7. Port Output (OUT1~OUT4).....	13
7-1. 1:1 Direct Output Implementation.....	13
7-2. LED PWM Output Implementation.....	14
7-3. Interrupt Output Implementation (OUT1/INT).....	15
8. CTRL Pin Selection.....	16
9. I <sup>2</sup> C-bus (SCL, SDA, A0).....	17
9-1. DEVICE ADDRESSING.....	18
9-2. WRITE OPERATION.....	18
9-3. READ OPERATION.....	18
10. REGISTER QUICK REFERENCE.....	19
11. REGISTER DESCRIPTION.....	20
11-1. Device Address (Address 00h).....	20
11-2. Device Status (Address 01h).....	20
11-3. Touch Output Status (Address 02h).....	20
11-4. Device Control (Address 06h).....	21
11-5. Touch Engine Control (Address 07h).....	21
11-6. Touch Sensitivity (Address 10h – 13h).....	22
11-7. LED PWM Brightness Control (Address 20h – 23h).....	22
12. Application Notes.....	23
12-1. Example Circuit (SOP14L PKG).....	23
12-2. Example Circuit (QFN16L PKG).....	24
12-3. Application Notes.....	25
13. PACKAGE DIMENSIONS.....	27
13-1. SOP14L PACKAGE.....	27
13-2. QFN16L PACKAGE.....	28

## 1. Absolute Maximum Ratings

Table 1. Absolute Maximum Rating<sup>(1)</sup>

Parameter	Symbol	Conditions	Min	Typ.	Max	Units
Maximum supply voltage	V <sub>DD_MAX</sub>		-		8.0	V
Supply voltage range <sup>(1)</sup>	V <sub>DD_RNG</sub>		2.2		6.0	V
Voltage on any input port	V <sub>IN_MAX</sub>		-		V <sub>DD</sub> +0.3	V
Maximum current into any port	I <sub>MIO</sub>		-100		100	mA
Power dissipation	P <sub>MAX</sub>		-		800	mW
Storage temperature	T <sub>STG</sub>		-65		150	°C
Operating humidity	H <sub>OP</sub>	8 hours	5		95	%
Operating temperature	T <sub>OPR</sub>		-40		85	°C
Junction temperature	T <sub>J</sub>		-40		125	°C

**Notes.**

(1) This is the real valid power supply voltage range considering allowable supply tolerance. It cannot be used as target supply voltage range which is separately presented at below 2. DC Electrical Characteristics.

## 2. DC Electrical Characteristics

Table 2. DC Electrical Characteristics<sup>(1)</sup>

Parameter	Symbol	Conditions	Min.	Typ.	Max.	Unit
<b>Power supply and current consumption</b>						
Target supply voltage	V <sub>DD</sub>		2.7	3.3 / 5.0	5.5	V
Current Consumption (Normal stand-by)	I <sub>DD</sub>			160		μA
Internal reset voltage <sup>(2)</sup>	V <sub>DD_RST</sub>	T <sub>A</sub> = 25°C	-	1.6	2.0	V
<b>Digital input/output</b>						
Input high level voltage	V <sub>IH</sub>		0.7V <sub>DD</sub>	-	V <sub>DD</sub> +0.3	V
Input low level voltage	V <sub>IL</sub>		-0.3	-	0.3V <sub>DD</sub>	V
Internal pull-up resistor (Ports : SCL, SDA)	R <sub>PU</sub>		-	30	-	kΩ
<b>Output (LED PWM) drive</b>						
Output sink current (LED drivable)	I <sub>SINK</sub>	Active low output <sup>(3)</sup>	-	-	10	mA
Output source current	I <sub>SRC</sub>	Active high output <sup>(3)</sup>	-	-	4	mA
Output impedance to GND (NMOS)	Z <sub>ON</sub>	Active low output (Low level) <sup>(3)</sup>	-	10	-	Ω
		Active low output (High level) <sup>(3)</sup>	-	30	-	MΩ
Output impedance to VDD (PMOS)	Z <sub>OP</sub>	Active high output (Low level) <sup>(3)</sup>	-	30	-	MΩ
		Active high output (High level) <sup>(3)</sup>	-	15	-	Ω
Output PWM duty steps (LED brightness steps)	N <sub>DUTY</sub>	LED output	-	32	-	step
Maximum PWM low duty (Maximum brightness)	D <sub>MAX(L)</sub>	LED output	-	100	-	%
Minimum PWM low duty (LED off)	D <sub>MIN(L)</sub>	LED output	-	0	-	%
PWM Frequency	F <sub>PWM</sub>		-	22	-	kHz
<b>Sensing Input ( SIN, RIN )</b>						
Minimum detectable input capacitance variation	ΔC <sub>S_MIN</sub>		0.1	-	-	pF
Max. SIN(RIN) input Capacitance	C <sub>SIN_MAX</sub> C <sub>RIN_MAX</sub>		-	-	100	pF
Sensitivity selection Steps	N <sub>SEN</sub>		-	60	-	step
Sense internal series resistor	R <sub>S</sub>		-	140	-	Ω
SIN external series resistor	R <sub>E_SIN</sub>		-	680	1000	Ω
<b>Timing for operations</b>						
Time for stable power Reset	T <sub>RST</sub>		-	100	-	msec
Start Time for I <sup>2</sup> C Communication after Power On	T <sub>com</sub>		-	-	20	usec
Touch Operating Time After Power On	T <sub>T</sub>		500	-	-	msec

**Notes.**

(1) Test condition: V<sub>DD</sub> = 3.3V, T<sub>A</sub> = 25 °C (Unless otherwise noted)

(2) The GT304L has internal reset circuit

(3) All the OUT ports can be selected as open-drain NMOS structure (Active Low) or as open drain PMOS structure (Active High).

Table 3. ESD Characteristics

Mode	Polarity	Min.	Reference
H.B.M	POSITIVE / NEGATIVE	8000 V	VDD
			VSS
			P to P
M.M	POSITIVE / NEGATIVE	500 V	VDD
			VSS
			P to P
CDM	POSITIVE / NEGATIVE	2000 V	Field induced

Table 4. Latch-Up Characteristics

Mode	Polarity	Max	Test Step
I-test	POSITIVE	200mA	25mA
	NEGATIVE	-200mA	
Vsupply Overvoltage Test	POSITIVE	~ 8.5V	-

## 3. I<sup>2</sup>C-bus Characteristics

Table 5. Characteristics of the SDA and SCL bus lines for I<sup>2</sup>C-bus devices<sup>(1)</sup>

PARAMETER	SYMBOL	STANDARD-MODE		FAST-MODE		Unit
		MIN.	MAX	MIN.	MAX.	
SCL clock frequency	f <sub>SCL</sub>	0	100	0	400	kHz
Hold time (repeated) START condition. After this period, the first clock pulse is generated	t <sub>HD;STA</sub>	4.0	-	0.6	-	us
LOW period of the SCL clock	t <sub>LOW</sub>	4.7	-	1.3	-	us
HIGH period of the SCL clock	t <sub>HIGH</sub>	4.0	-	0.6	-	us
Set-up time for a repeated START condition	t <sub>SU;STA</sub>	4.7	-	0.6	-	us
Data hold time: for CBUS compatible masters (see NOTE, Section 10.1.3) for I2C-bus devices	t <sub>HD;DAT</sub>	5.0 0 <sup>(2)</sup>	- 3.45 <sup>(3)</sup>	- 0 <sup>(2)</sup>	- 0.9 <sup>(3)</sup>	us
Data set-up time	t <sub>SU;DAT</sub>	250	-	100 <sup>(4)</sup>	-	ns
Rise time of both SDA and SCL signals	t <sub>r</sub>	-	1000	20 + 0.1 C <sub>b</sub> <sup>(5)</sup>	300	ns
Fall time of both SDA and SCL signals	t <sub>f</sub>	-	300	20 + 0.1 C <sub>b</sub> <sup>(5)</sup>	300	ns
Set-up time for STOP condition	t <sub>SU;STO</sub>	4.0	-	0.6	-	us
Bus free time between a STOP and START condition	t <sub>BUF</sub>	4.7	-	1.3	-	us
Capacitive load for each bus line	C <sub>b</sub>	-	400		400	pF
Noise margin at the LOW level for each connected device (including hysteresis)	V <sub>nL</sub>	0.1V <sub>DD</sub>	-	0.1V <sub>DD</sub>	-	V
Noise margin at the HIGH level for each connected device (including hysteresis)	V <sub>nH</sub>	0.2V <sub>DD</sub>	-	0.2V <sub>DD</sub>	-	V

### Notes

- (1) All values referred to V<sub>IH</sub> and V<sub>IL</sub> levels (see Table 2-1).
- (2) A device must internally provide a hold time of at least 300 ns for the SDA signal (referred to the V<sub>IH</sub> of the SCL signal) to bridge the undefined region of the falling edge of SCL.
- (3) The maximum t<sub>HD;DAT</sub> has only to be met if the device does not stretch the LOW period (t<sub>LOW</sub>) of the SCL signal.  
(4) A Fast-mode I<sup>2</sup>C-bus device can be used in a Standard-mode I<sup>2</sup>C-bus system, but the requirement t<sub>SU;DAT</sub> ≥ 250 ns must then be met. This will automatically be the case if the device does not stretch the LOW period of the SCL signal. If such a device does stretch the LOW period of the SCL signal, it must output the next data bit to the SDA line t<sub>r</sub> max + t<sub>SU;DAT</sub> = 1000 + 250 = 1250 ns (according to the Standard-mode I<sup>2</sup>C-bus specification) before the SCL line is released.
- (5) C<sub>b</sub> = total capacitance of one bus line in pF.

n/a = not applicable

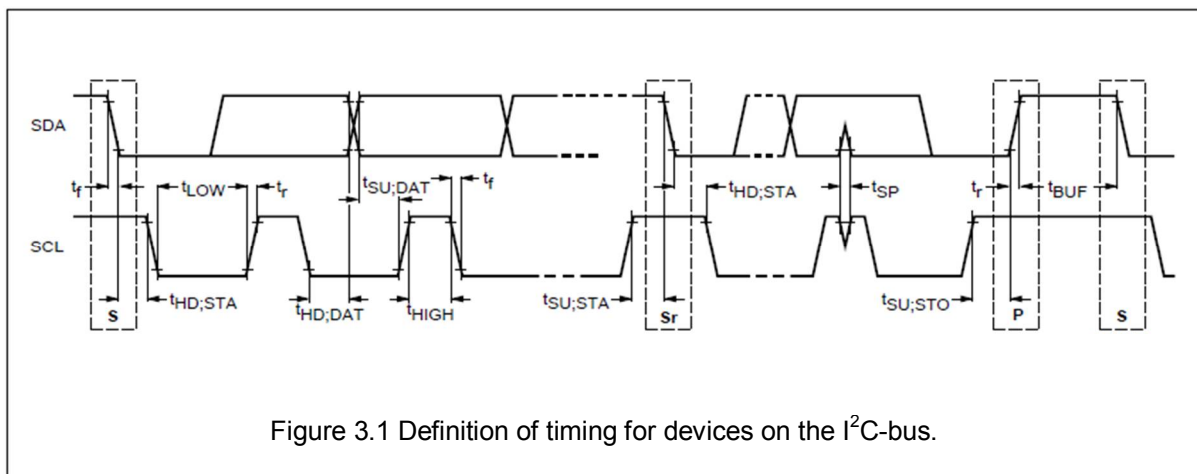



## 4. Pinout Information

### 4-1. SOP14L PACKAGE

Table 6. Pin Definitions for the SOP14L PACKAGE

Port No.	Name	Type	Description
1	SDA	DIO	I <sup>2</sup> C serial data port.
2	VDD	PWR	Power Supply Voltage Input.
3	SCL	DI	I <sup>2</sup> C serial clock port.
4	SIN1	AI	Touch Sensing Input ( channel 1)
5	SIN2	AI	Touch Sensing Input ( channel 2)
6	SIN3	AI	Touch Sensing Input ( channel 3)
7	RIN	AI	Touch Sensing Input ( Reference )
8	CTRL/A0	DI	Sensitivity control input Address A0 bit for I <sup>2</sup> C serial interface
9	SIN4	AI	Touch Sensing Input ( channel 4)
10	OUT1/INT	DO	1:1 direct output port for SIN1 / LED PWM drive output Interrupt output signal when touch status is changed.
11	OUT2	DO	1:1 direct output port for SIN2 / LED PWM drive output
12	GND	-	Ground.
13	OUT3	DO	1:1 direct output port for SIN3 / LED PWM drive output
14	OUT4	DO	1:1 direct output port for SIN4 / LED PWM drive output

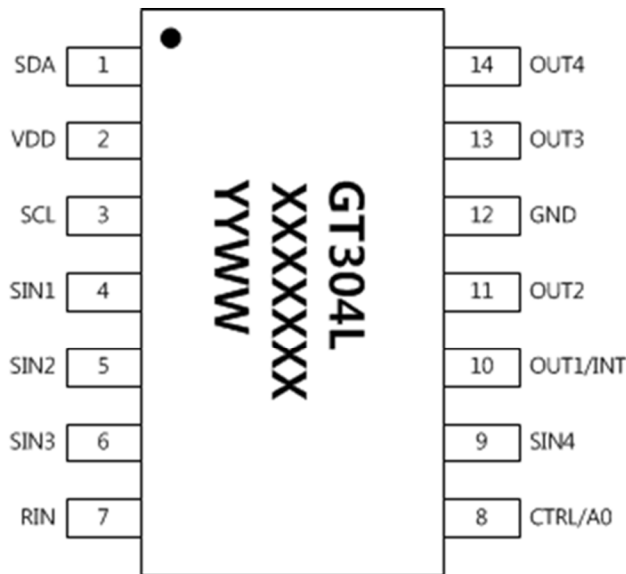

Figure 4.1 SOP14L Pinout Diagram (Top View)

## 4-2. QFN16L PACKAGE

Table 7. Pin Definitions for the QFN16L PACKAGE

Port No.	Name	Type	Description
1	N.C	-	
2	SCL	DI	I <sup>2</sup> C serial clock port.
3	N.C	-	
4	SIN1	AI	Touch Sensing Input ( channel 1)
5	SIN2	AI	Touch Sensing Input ( channel 2)
6	SIN3	AI	Touch Sensing Input ( channel 3)
7	RIN	AI	Touch Sensing Input ( Reference )
8	CTRL/A0	DI	Sensitivity control input Address A0 bit for I <sup>2</sup> C serial interface
9	SIN4	AI	Touch Sensing Input ( channel 4)
10	OUT1/INT	DO	1:1 direct output port for SIN1 / LED PWM drive output Interrupt output signal when touch status is changed.
11	OUT2	DO	1:1 direct output port for SIN2 / LED PWM drive output
12	GND	-	Ground.
13	OUT3	DO	1:1 direct output port for SIN3 / LED PWM drive output
14	OUT4	DO	1:1 direct output port for SIN4 / LED PWM drive output
15	VDD	PWR	Power Supply Voltage Input.
16	SDA	DIO	I <sup>2</sup> C serial data port.

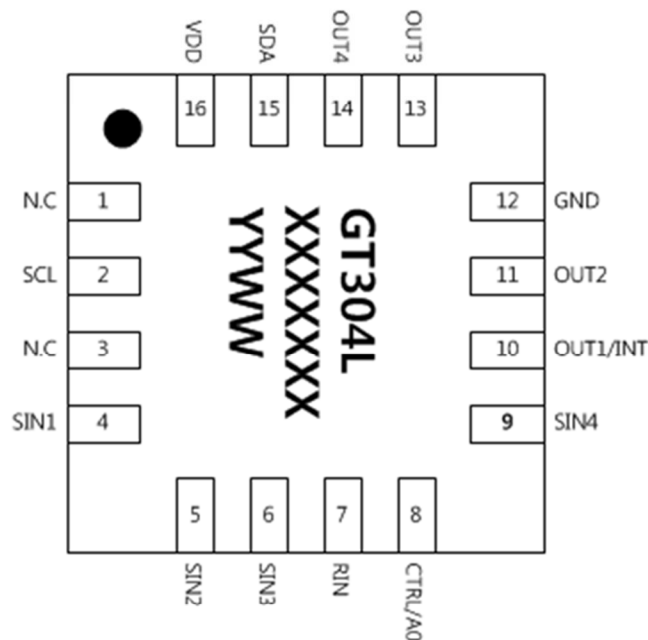
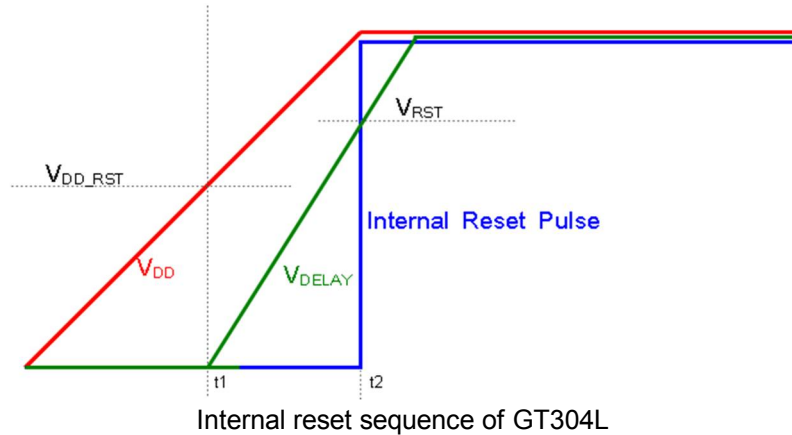

Figure 4.2 QFN16L Pinout Diagram (Top View)

## 5. Internal POWER-ON RESET

The GT304L has internal power reset functions. The internal reset operation is used for initial power reset.

The internal power reset sequence is represented as below.



The internal  $V_{DELAY}$  voltage starts to rise when  $V_{DD}$  come up to  $V_{DD\_RST}$  level. The internal reset pulse is maintained as low between  $t_1$  and  $t_2$ . During this low pulse period, the internal power reset operation is finished. Every time when  $V_{DD}$  drops under  $V_{DD\_RST}$  internal reset block makes  $V_{DELAY}$  signal low and then internal reset pulse drops to low. By above internal reset operation sequence GT304L gets more certain and more correct power reset function than any others.

## 6. Touch Sensing Input Implementation (RIN, SIN)

SIN inputs (SIN1~SIN4) and RIN input are used for touch detection of capacitance variation sensing. The SIN input pins are connected to touch sensing pad and catches capacitance variation caused by direct touch or approach. And RIN input for the reference capacitance is connected only to a capacitor to compensate capacitance difference between SIN inputs and RIN input. The GT304L compares each capacitance of SIN input and that of RIN input and determines touch detection of each channel when capacitance of each SIN input increases. So, for correct capacitance comparison between SIN inputs and RIN input, approximately equal initial-steady state capacitance between SIN inputs and RIN input are recommended. User can compensate initial-steady state capacitance difference between SIN inputs and RIN input by adding capacitor to RIN pin. Experimentally, proper  $C_{RIN}$  capacitor value is about the average value of SIN inputs capacitors.

The GT304L also has various intelligent sensing functions to determine valid touch from error or sensitivity problems caused by various environmental noise effects. These advanced sensing methods will help making faultless touch key systems under the worst conditions.

With sensitivity options by CTRL pin and  $C_{SIN1-4}$  capacitors, there will be no difficulties to satisfy system's required sensitivity. The internal intelligent sensitivity adjustment algorithm removes sensitivity rolling caused by system noise, circuit deviation, and circumstantial drift. The GT304L has a special noise elimination filter for more powerful noise rejection and it will be very helpful for proper touch operation even if the system operates under deteriorative environment conditions.

Implementation circuit for SIN inputs and RIN input is shown in figure below. The GT304L SIN inputs have an internal series resistor for ESD protection. The additional external series resistors are profitable for prevention of abnormal actions caused by radiation noise or electrical surge pulse. In any case, if the additional external series resistor ( $R_{E\_SIN}$ ) of each SIN input is required, then it should be less than 1k $\Omega$  and the location of resistor is recommended as closer to the SIN pins. For  $C_{SIN1-4}$ ,  $C_{RIN}$  capacitor, less than 50pF capacitor can be used. Both  $R_{E\_SIN}$  and  $C_{SIN1-4}$  are not obligatory components.

The SIN input routing lines are desirable to be routed as short as possible and the width of routing lines should be as narrow as possible and should be placed on bottom metal. In other words, a touch PAD and other parts should be placed on different metal each other. The additional extension line pattern of RIN input on application PCB can help prevention of abnormal actions caused by radiation noise, but excessive long RIN input line can be a reason for failure of touch detect. The SIN inputs and RIN input lines are desirable to be routed as far as possible from impedance varying path such as LED drive current path. All touch sensing pads are recommended to be surrounded by GND pattern in order to reduce noise influence.

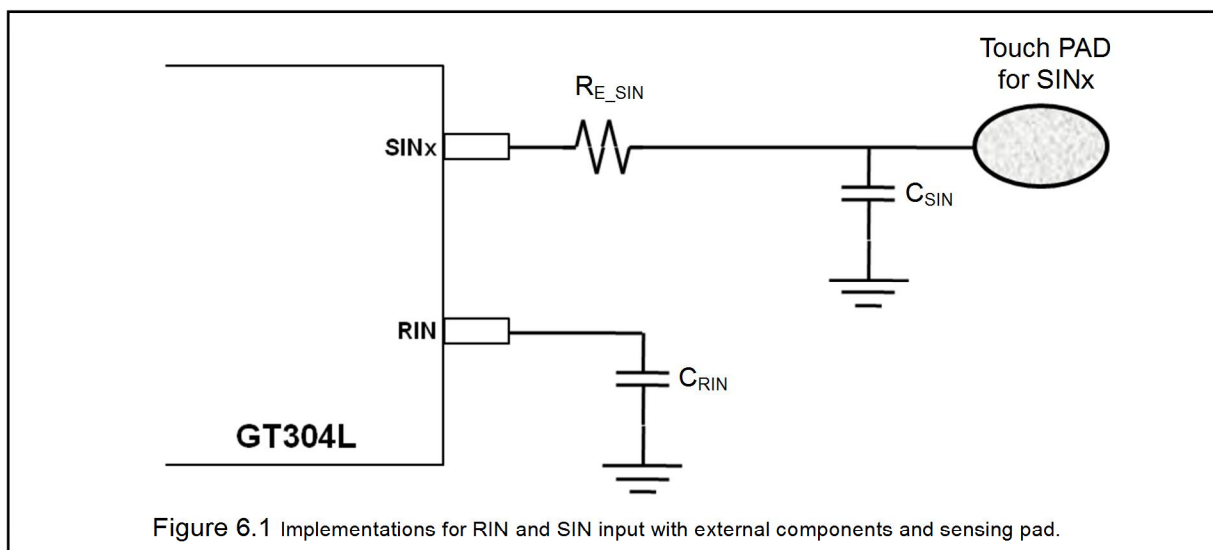
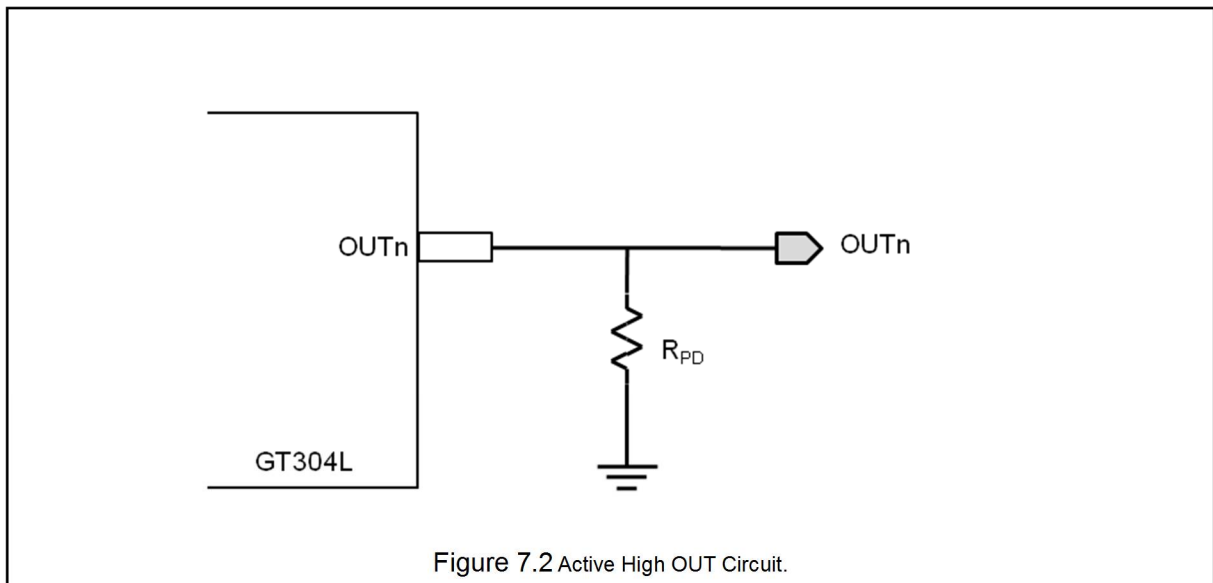
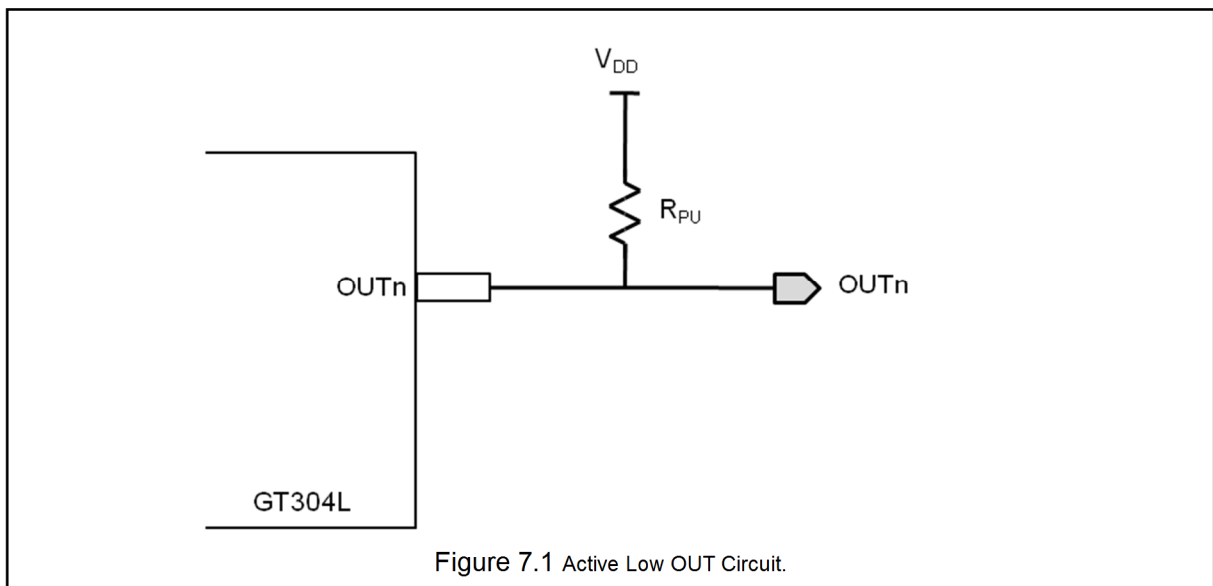

Figure 6.1 Implementations for RIN and SIN input with external components and sensing pad.

## 7. Port Output (OUT1~OUT4)

### 7-1. 1:1 Direct Output Implementation

The GT304L has two types of output data interface methods. The first method is 1 to 1 direct output using from the OUT1 to OUT4 pins which are corresponding to SIN1 to SIN4 respectively. (Output pins OUTx corresponds to sensing channel of SINx) The other one is I<sup>2</sup>C interface using SCL and SDA pins. This two interface methods can be used simultaneously. These 1 to 1 direct output pins can operate in active low or active high mode. Its polarity of output can be changed with 'DIR\_OUT\_POL' register bit and all OUTx pins will have the same active polarity. The OUTx pins have open drain NMOS structure so therefore it needs pull-up resistors when the OUTx pins are used in active low mode. They also have open drain PMOS structure and they need pull-down resistors in active high mode. A couple of kΩ can be used for these pull-up or pull-down resistors. The implementations for both two active modes are shown in figures following.



## 7-2. LED PWM Output Implementation

The LED PWM drive is available by using output pins from OUT1 to OUT4. There are 32 steps for the LED brightness and it is controlled by PWM control register. The maximum LED brightness is on 100% duty and the minimum is on 0% duty. The maximum sink current is 10mA on each pin under typical condition. The OUTn pins can't be used for 1 to 1 direct touch sensing output simultaneously when it is used for driving LED. The basic implementation for LED PWM drive is shown in figure below. The  $R_{PU}$  are LED current limiting resistors.

( See. 11-5 Device Control )

( See. 11-8 LED PWM Brightness Control )

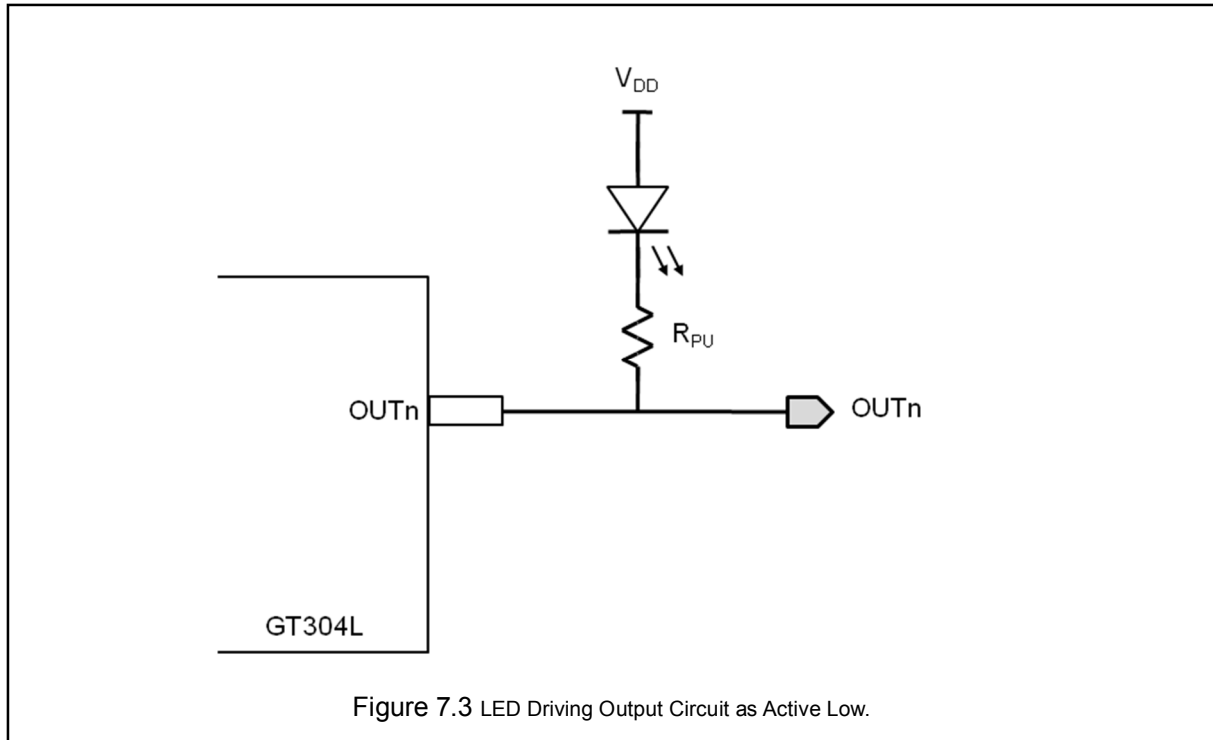
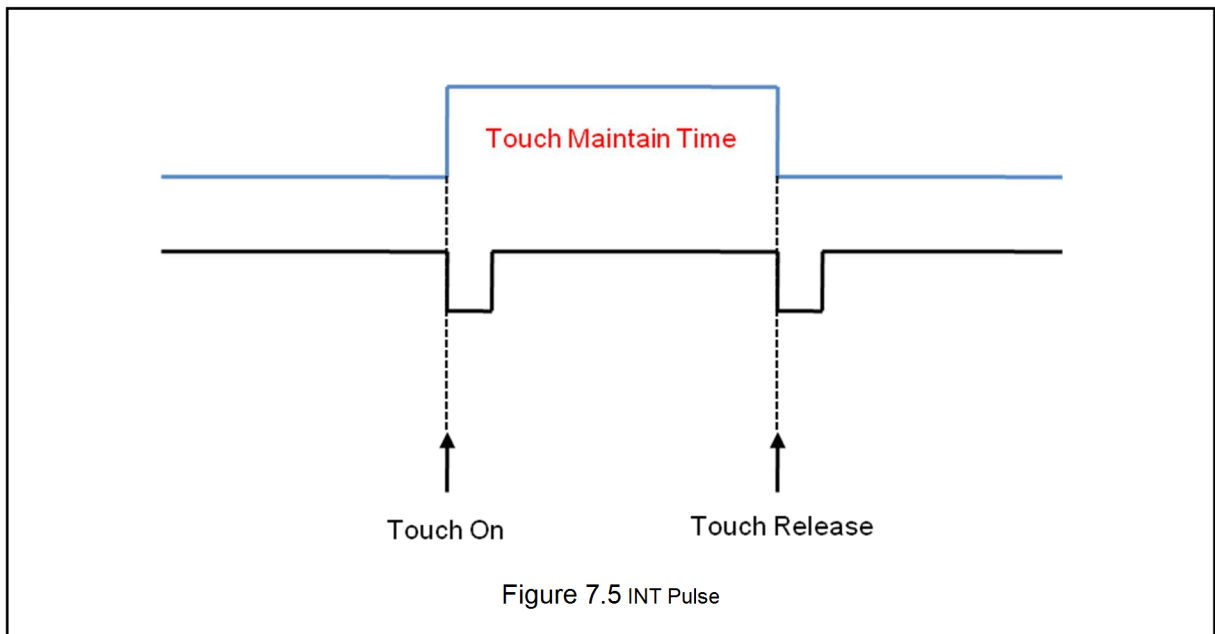
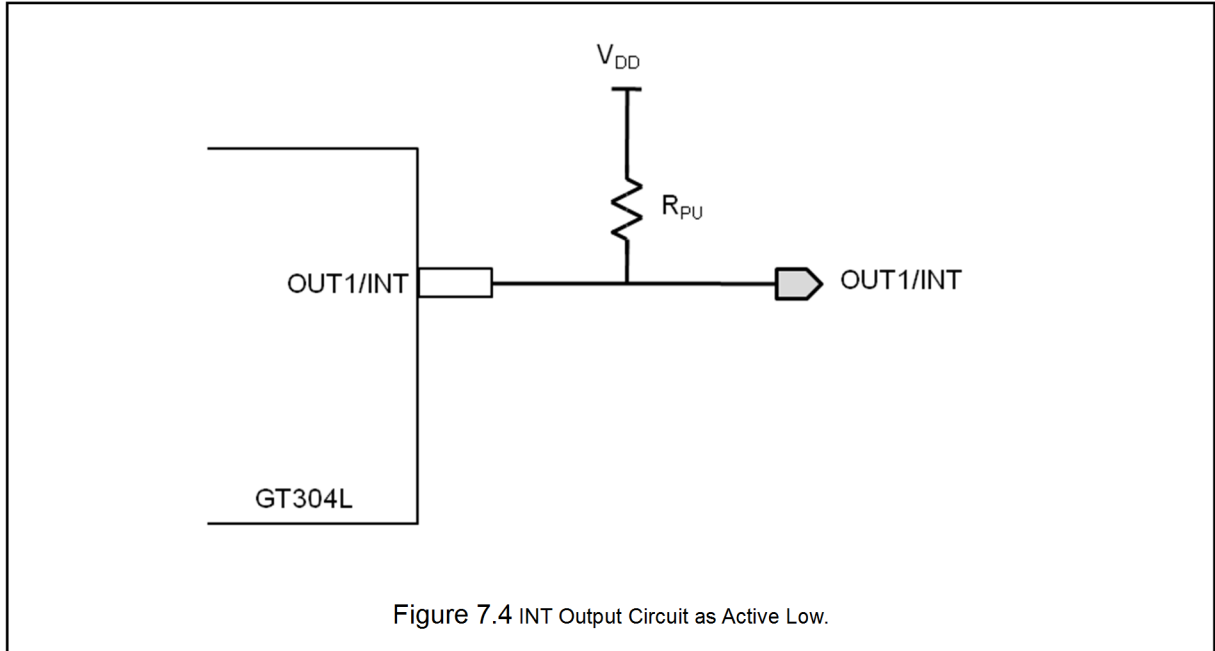

Figure 7.3 LED Driving Output Circuit as Active Low.

### 7-3. Interrupt Output Implementation (OUT1/INT)

The GT304L provides an interrupt (INT) function to reduce a communication load between MCU and GT304L. The INT will indicate a point of time that the output status registers at the address 0x02 changes and MCU needs to read it. The INT pin has an open drain NMOS structure hence a couple of kΩ pull-up resistor must be required. OUT1/INT is used an dual-purpose pin in register (See. 11-5 Device Control)



## 8. CTRL Pin Selection

In the GT304L, two options are available by CTRL pin connection. Each option and its connections are shown in the table and figures below. This CTRL pulse signal starts at internal power reset time and finishes after a few operation period and options setting. For more detail sensitivity adjustment,  $C_{SIN}$  capacitors should be used. (See. Touch Sensing Input Implementation (RIN, SIN)).

Table 8. CTRL Option Lists.

CTRL pin connection	
<p><b>[CASE 1] GND Connection</b></p> <ul style="list-style-type: none"> <li>➤ High Sensitivity ( 0x0A )</li> <li>➤ I<sup>2</sup>C-bus DEVICE ADDRESS '0xB4'</li> </ul>	<p><b>[CASE 2] VDD Connection</b></p> <ul style="list-style-type: none"> <li>➤ Low Sensitivity ( 0x0F )</li> <li>➤ I<sup>2</sup>C-bus DEVICE ADDRESS '0xB6'</li> </ul>

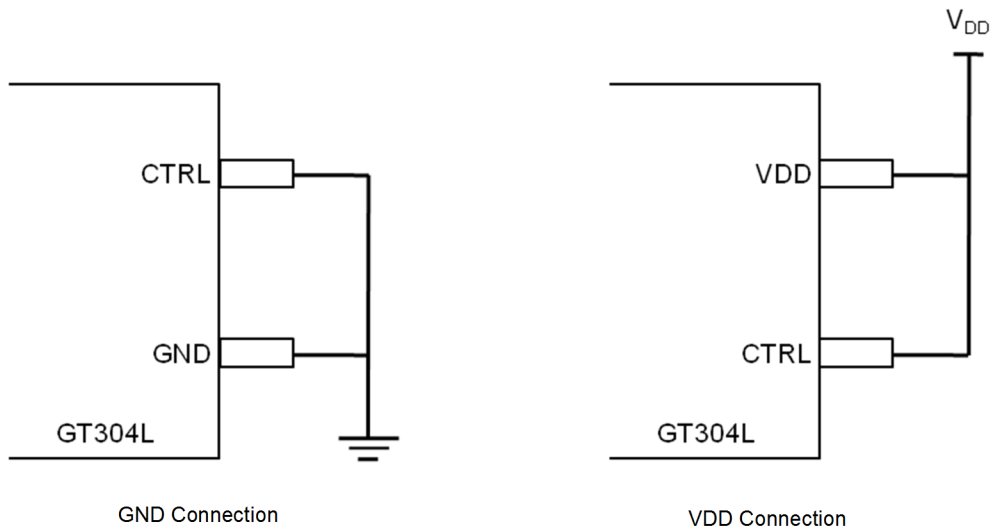

Figure 8.1 CTRL Connection



## 9. I<sup>2</sup>C-bus (SCL, SDA, A0)

The I<sup>2</sup>C-bus is for 2-way, 2-line communication between different ICs or modules. The serial bus consists of two bidirectional lines; one for data signals (SDA), and one for clock signals (SCL).

Both the SDA and SCL lines be connected to a positive supply voltage via a internal pull-up resistor (typical 30kΩ) to prevent open gate leakage current in input mode. But the lines must be connected to a positive supply voltage via a pull-up additional external resistor.

The internal oscillator is disabled when all of both the SDA and SCL lines are high. For saving current consumption.

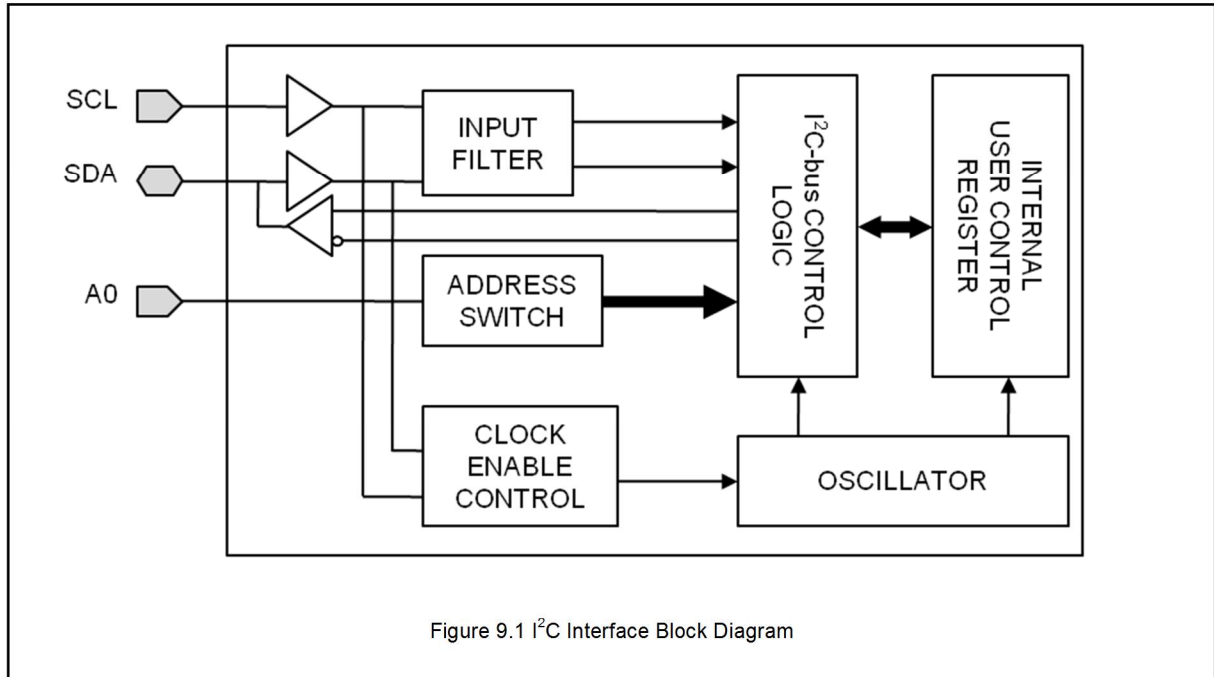

## 9-1. DEVICE ADDRESSING

Following a START condition, the bus master must output the address of the slave it is accessing. The address of the GT304L is shown in **Figure 9.2**. To conserve power, no internal pull-up resistors are incorporated on the hardware selectable pins(A0) and it must be connected to either VDD or GND. Bit[3] and bit[2] are changeable by register. See 11-1 Device Address (Address 00h).

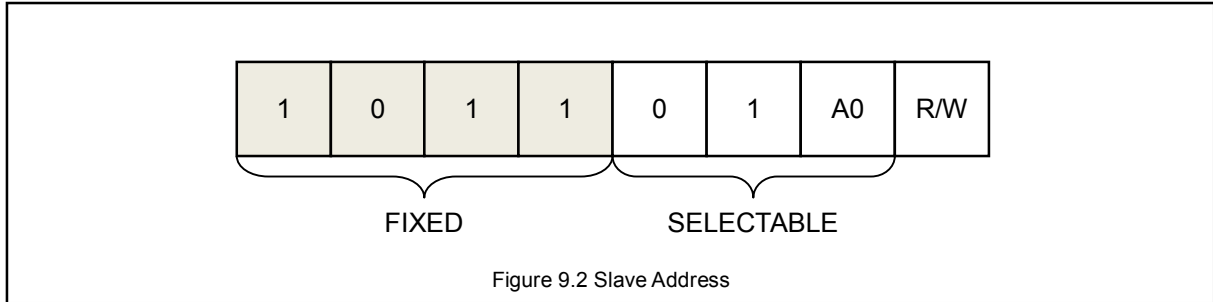

The last bit of the slave address defines the operation to be performed. When set to logic 1, a read operation is selected, while a logic 0 selects a write operation.

## 9-2. WRITE OPERATION

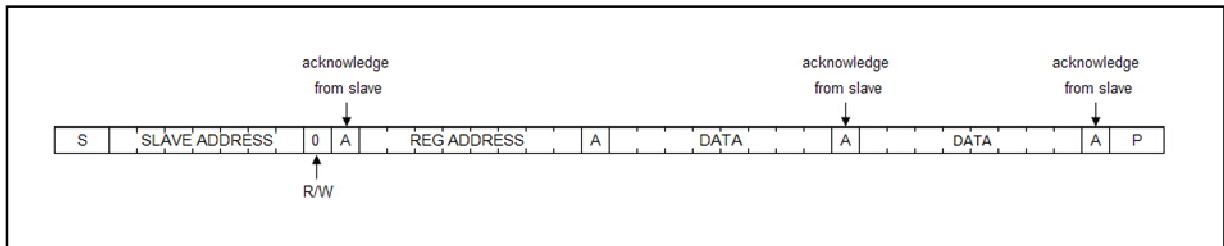

## 9-3. READ OPERATION

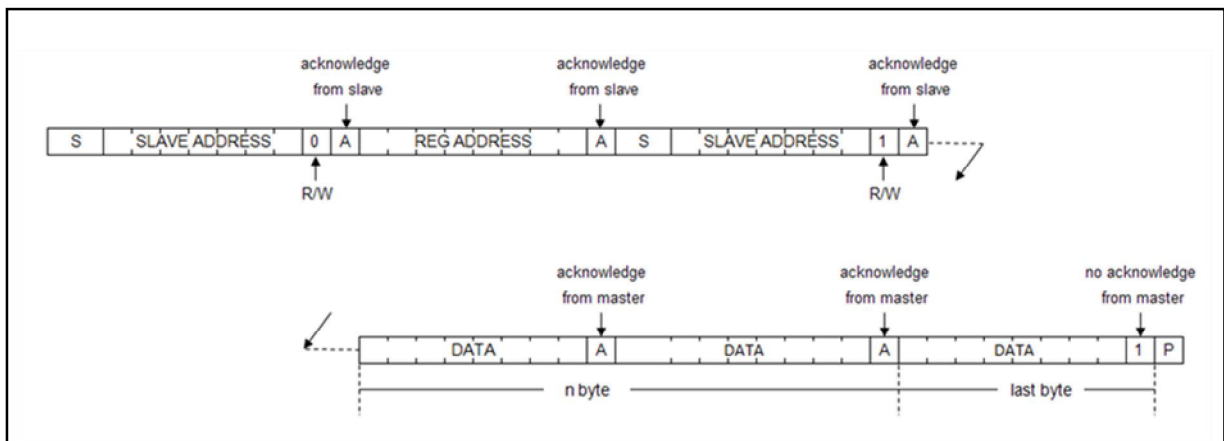

## 10. REGISTER QUICK REFERENCE

**WARNING:** All “Reserved” registers must maintain their default state to ensure proper functional operation.

Table 9. REGISTER MAP

Addr.	Def.	Bit 7	Bit 6	Bit 5	Bit 4	Bit 3	Bit 2	Bit 1	Bit 0
00H	0xB4 or 0xB6	Reserved				ADDR[3:2]		A0	Reserved
01H	0x01	Reserved							RST
02H	-	Reserved				TOUCH OUT4	TOUCH OUT3	TOUCH OUT2	TOUCH OUT1
06H	0x41	SLEEP	EN_ MULTI	EN_ PWM	EN_INT	OUT_ POL	SEN_IDLE_TIME		
07H	0x27	Reserved	TOUCH_PER			CAL_TIME			
10H	0x0A or 0x0F	Reserved		SENSITIVITY1					
11H		Reserved		SENSITIVITY2					
12H		Reserved		SENSITIVITY3					
13H		Reserved		SENSITIVITY4					
20H	0x00	Reserved			PWM_DATA1				
21H	0x00	Reserved			PWM_DATA2				
22H	0x00	Reserved			PWM_DATA3				
23H	0x00	Reserved			PWM_DATA4				

## 11. REGISTER DESCRIPTION

### 11-1. Device Address (Address 00h)

- Description: The I<sup>2</sup>C-bus master must output the address of the slave it is accessing.  
See. 9-1 DEVICE ADDRESSING

Bit 7	Bit 6	Bit 5	Bit 4	Bit 3	Bit 2	Bit 1	Bit 0
Reserved				ADDR[3:2]		A0	Reserved
1	0	1	1	0	1	A0	0

ADDR[3:2]	Slave address bit[3:2].	RW
A0	Set by A0 Pin.	R

### 11-2. Device Status (Address 01h)

- Description: Indicate the status of GT304L.

Bit 7	Bit 6	Bit 5	Bit 4	Bit 3	Bit 2	Bit 1	Bit 0
Reserved							RST
0	0	0	0	0	0	0	1

RST	Set '1' after POWER-ON RESET	RW
-----	------------------------------	----

### 11-3. Touch Output Status (Address 02h)

- Description: An each touch channel output status can be monitored..

Bit 7	Bit 6	Bit 5	Bit 4	Bit 3	Bit 2	Bit 1	Bit 0
Reserved				TOUCH OUT4	TOUCH OUT3	TOUCH OUT2	TOUCH OUT1
0	0	0	0	0	0	0	0

TOUCH OUT4	Set '1' when touch-on of SIN4 is detected	R
TOUCH OUT3	Set '1' when touch-on of SIN3 is detected	R
TOUCH OUT2	Set '1' when touch-on of SIN2 is detected	R
TOUCH OUT1	Set '1' when touch-on of SIN1 is detected	R

### 11-4. Device Control (Address 06h)

➤ Description: The GT304L can be controlled for meeting various user applications.

Bit 7	Bit 6	Bit 5	Bit 4	Bit 3	Bit 2	Bit 1	Bit 0
SLEEP	EN_MULTI	EN_PWM	EN_INT	OUT_POL	SEN_IDLE_TIME		
0	1	0	0	0	0	0	1

SLEEP	Current consumption can be saved in sleep mode and Touch Engine is initialized when falling edge occur. The values of registers are not changed. 0 : Operation mode 1 : Sleep mode.	RW
EN_MULTI	0 : Single touch mode 1 : Multi touch mode.	RW
EN_PWM	0 : PWM mode disable 1 : PWM mode enable. <i>See. 7-2 LED PWM Output Implementation</i>	RW
EN_INT	0 : INT mode disable 1 : INT mode enable. <i>See. 7-3 Interrupt Output Implementation (OUT1/INT)</i>	RW
OUT_POL	0 : Active Low Output 1 : Active High Output <i>See. 7-3 1:1 Direct Output Implementation</i>	RW
SEN_IDLE_TIME	000 : about 3ms 001 : about 18ms 010 : about 60ms 011 : about 120ms 100 : about 240ms 101 : about 360ms 110 : about 480ms 111 : about 600ms *Deviation : ±30%	RW

### 11-5. Touch Engine Control (Address 07h)

➤ Description: The GT304L can be controlled calibration time for optimal performance against environmental change in user application.

Bit 7	Bit 6	Bit 5	Bit 4	Bit 3	Bit 2	Bit 1	Bit 0
Reserved	TOUCH_PER			CAL_TIME			
0	0	1	0	0	1	1	1

TOUCH_PER	The continuous period for touch detection.	RW
CAL_TIME	The calibration time to protect from environmental change 0000 : + 1 period                      1000 : 480ms + 1 period 0000 : 60ms + 1 period                1001 : 540ms + 1 period 0010 : 140ms + 1 period               1010 : 600ms + 1 period	RW

0011 : 180ms + 1 period	1011 : 660ms + 1 period
0100 : 240ms + 1 period	1100 : 720ms + 1 period
0101 : 300ms + 1 period	1101 : 780ms + 1 period
0110 : 360ms + 1 period	1110 : 840ms + 1 period
0111 : 420ms + 1 period	1111 : 900ms + 1 period
*Deviation : ±30%	

### 11-6. Touch Sensitivity (Address 10h – 13h)

- Description: The GT304L can be controlled independently for getting the optimal sensitivity on each channel (SINn).

Bit 7	Bit 6	Bit 5	Bit 4	Bit 3	Bit 2	Bit 1	Bit 0
Reserved		SENSITIVITYn					
0	0	-	-	-	-	-	-

SENSITIVITYn	Touch sensitivity for SINn Default value by CTRL Pin. See. 8. Sensitivity (CTRL)  CTRL=GND : 0x0A CTRL=VDD : 0x0F	RW
--------------	--	----

### 11-7. LED PWM Brightness Control (Address 20h – 23h)

- Description: The GT304L support LED PWM dimming function. The brightness is changeable by the register.

Bit 7	Bit 6	Bit 5	Bit 4	Bit 3	Bit 2	Bit 1	Bit 0
Reserved			PWM DATA <sub>n</sub>				
0	0	0	0	0	0	0	0

PWM_DATA	LED PWM Brightness is controlled within 32 Steps. 06h[4]EN_PWM should be set '1'. See. 7-2 LED PWM Output Implementation	RW
----------	--	----

## 12. Application Notes

### 12-1. Example Circuit (SOP14L PKG)

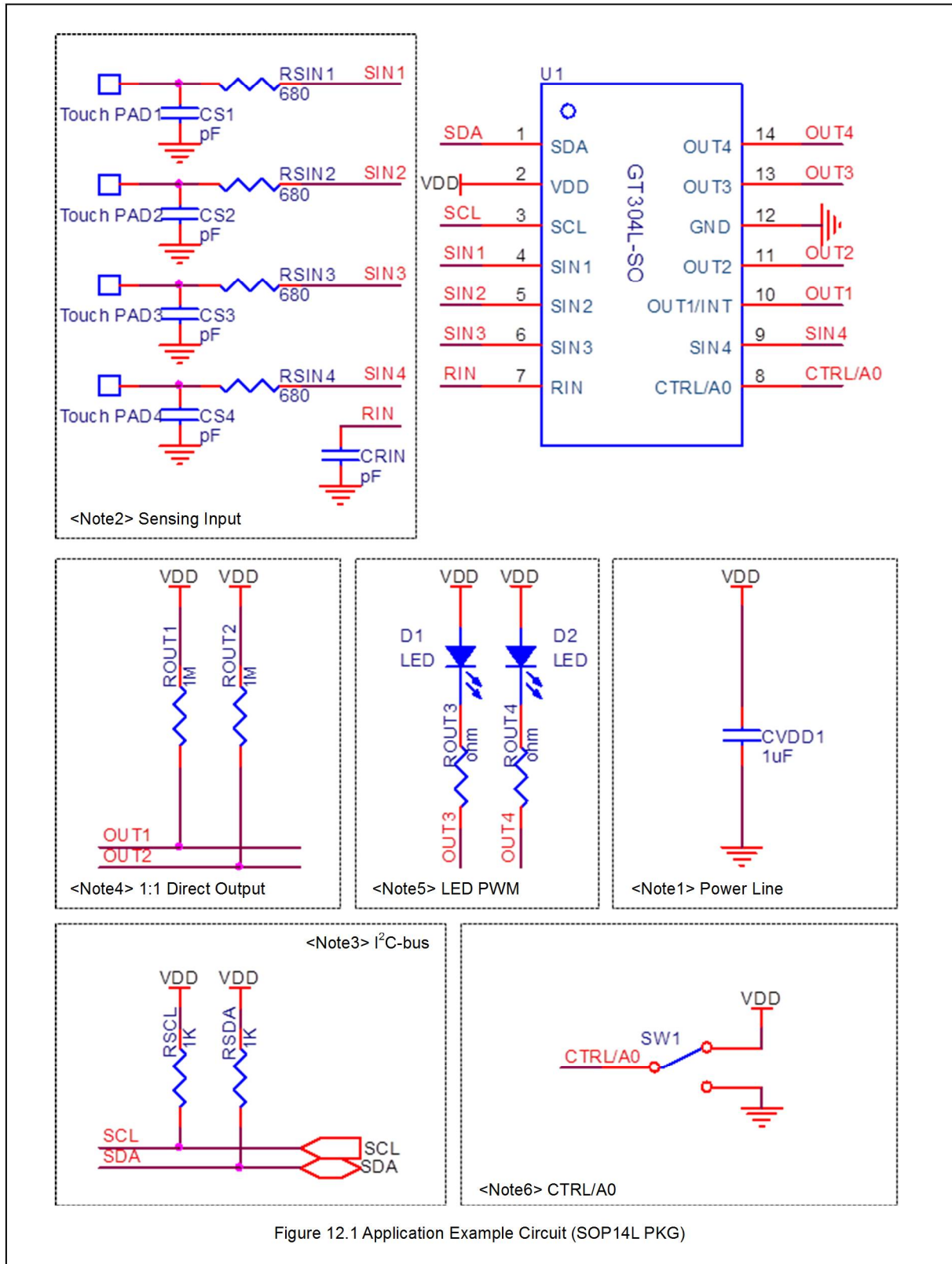

Figure 12.1 Application Example Circuit (SOP14L PKG)

## 12-2. Example Circuit (QFN16L PKG)

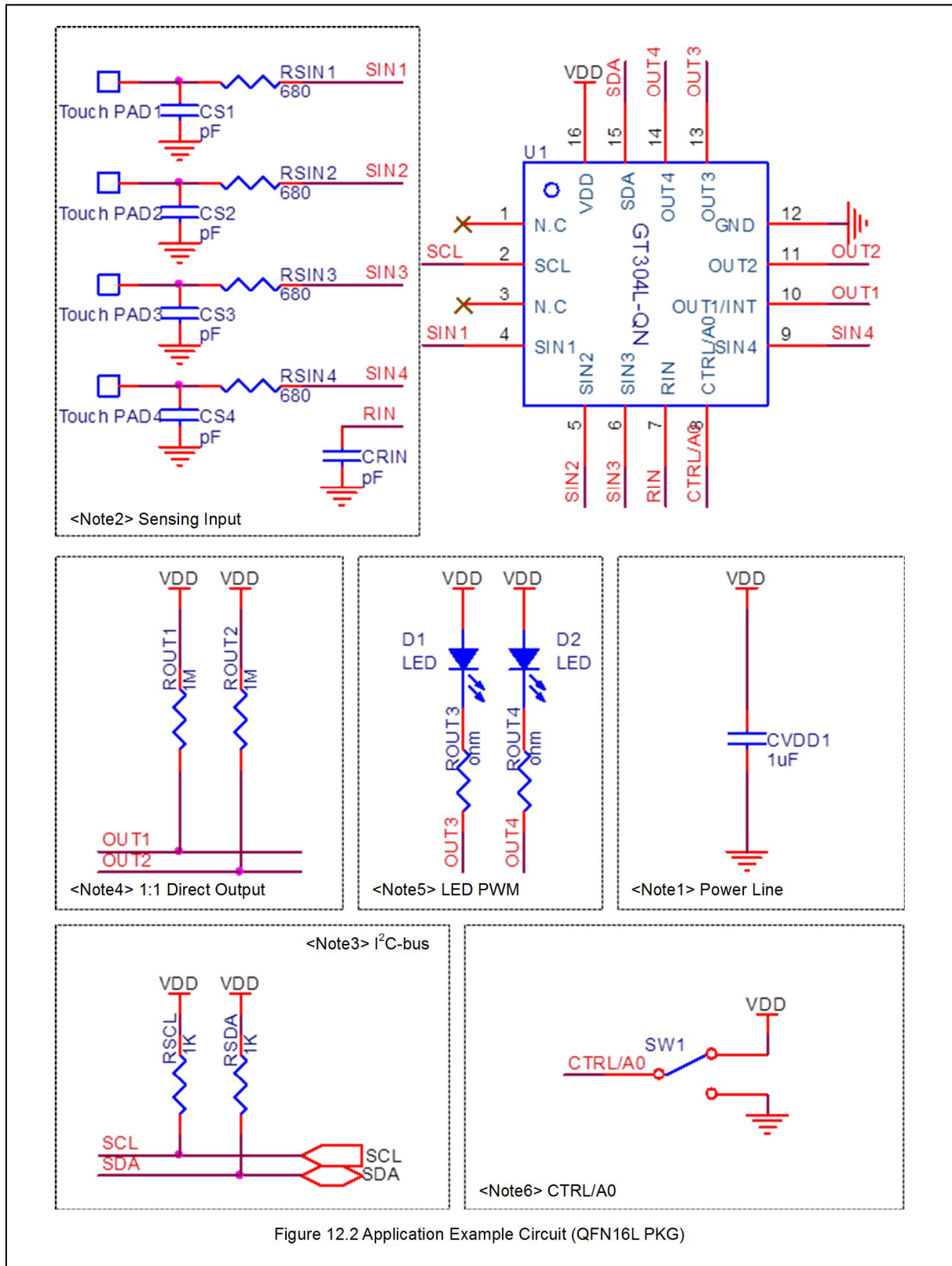

Figure 12.2 Application Example Circuit (QFN16L PKG)



## 12-3. Application Notes

Normally a touch sensing operation is ultimately impedance variation sensing. Hence a touch sensing system is recommended to be taken care of prevention of the external sensing disturbance. Although the GT304L has enough noise rejection algorithms and various internal protection circuits to prevent error touch detection caused by noise and incapable sensing, it is better to take care in noisy applications such as home appliances. There are many measurable or invisible noises in system that can affect the impedance sensing signal or distort that signal. The main principal design issues and required attentions are such as below.

### 12-2.1 Power Line <Note1>

- The touch sensor power line is recommended to be split from the other power lines such as relay circuits or LED power that can make pulsation noise on power lines.
- The big inductance that might exist in long power connection line can cause power fluctuation by other noise sources.
- The lower frequency periodic power noise such as a few Hz ~ kHz has more baneful influence on sensitivity calibration.
- An extra regulator for touch sensor is desirable for prevention above power line noises.
- The  $V_{DD}$  under shooting pulse less than internal reset voltage ( $V_{DD\_RST}$ ) can cause system reset.
- The capacitor connected between  $V_{DD}$  and GND is somehow obligation element for buffering above power line noises. This capacitor must be placed as near to IC as possible.

### 12-2.2 Sensing Input <Note2>

- The sensing lines for touch detection are desirable to be routed as short as possible and the width of routing path should be as narrow as possible.
- The sensing line for touch detection should be formed by bottom metal, in other words, an opposite metal of a touch PAD.
- The additional extension line pattern of RIN input on application PCB can help prevention of abnormal actions caused by radiation noise, but excessive long RIN input line can be a reason for failure of touch detect.
- SIN capacitor is useful for sensitivity reduction adjust. A bigger capacitor of SIN makes sensitivity of corresponding channel to be lower.
- RIN capacitor value is about average value of total capacitance of each SIN touch sensing inputs.
- The sensing line for touch detection is desirable to be routed as far as possible from impedance varying path such as LED drive current path.
- An unused sensing channel is desirable to be turned off by control register (See. 11-4 *Touch Enable*). (Recommendation)
- Additional external series resistors are profitable for prevention of abnormal actions caused by radiation noise or electrical surge pulse. The series resistor value should be less than 1k $\Omega$  and the location of resistor is better as near as possible to the SIN ports for better stable operation.
- All touch sensing pads are recommended to be surrounded by GND pattern to reduce noise influence.
- **Not used SIN channel must be open.**

### 12-2.3 I<sup>2</sup>C-bus <Note3>

- The SCL is I<sup>2</sup>C clock input port and SDA is I<sup>2</sup>C data input/output port. SCL and SDA have internal optional pull-up resistor. So, when I<sup>2</sup>C interface is not required, SCL and SDA ports can be floating. For high speed communication, the lines must be connected to a positive supply voltage via a pull-up additional external resistor.

### 12-2.4 1:1 Direct Output <Note4>

- The OUT ports that are used as 1:1 direct output purpose. The lines must be connected to a positive supply voltage via a pull-up external resistor or GND via a pull-down external resistor.
- Each OUT ports has sinking current ability and sourcing current ability.

## 12-2.5 LED PWM <Note5>

- The OUT ports that are used as LED PWM Output purpose. The lines must be connected to a positive supply voltage via a pull-up external resistor and LED or GND via a pull-down external resistor and LED.
- The maximum 10mA LED drive current can be sunk by a single OUT port on typical temperature condition. The OUT ports which are used as LED PWM drive ports cannot carry out the role of 1 to 1 direct out simultaneously.
- The 32 steps brightness control is possible.  
( See. 11-5 Device Control )  
( See. 11-7 LED PWM Brightness Control )

## 12-2.6 CTRL/A0 <Note6>

- CTRL/A0 Pin must be connected to either VDD or GND. **The OPEN connection is forbidden.**

## 13. PACKAGE DIMENSIONS

### 13-1. SOP14L PACKAGE

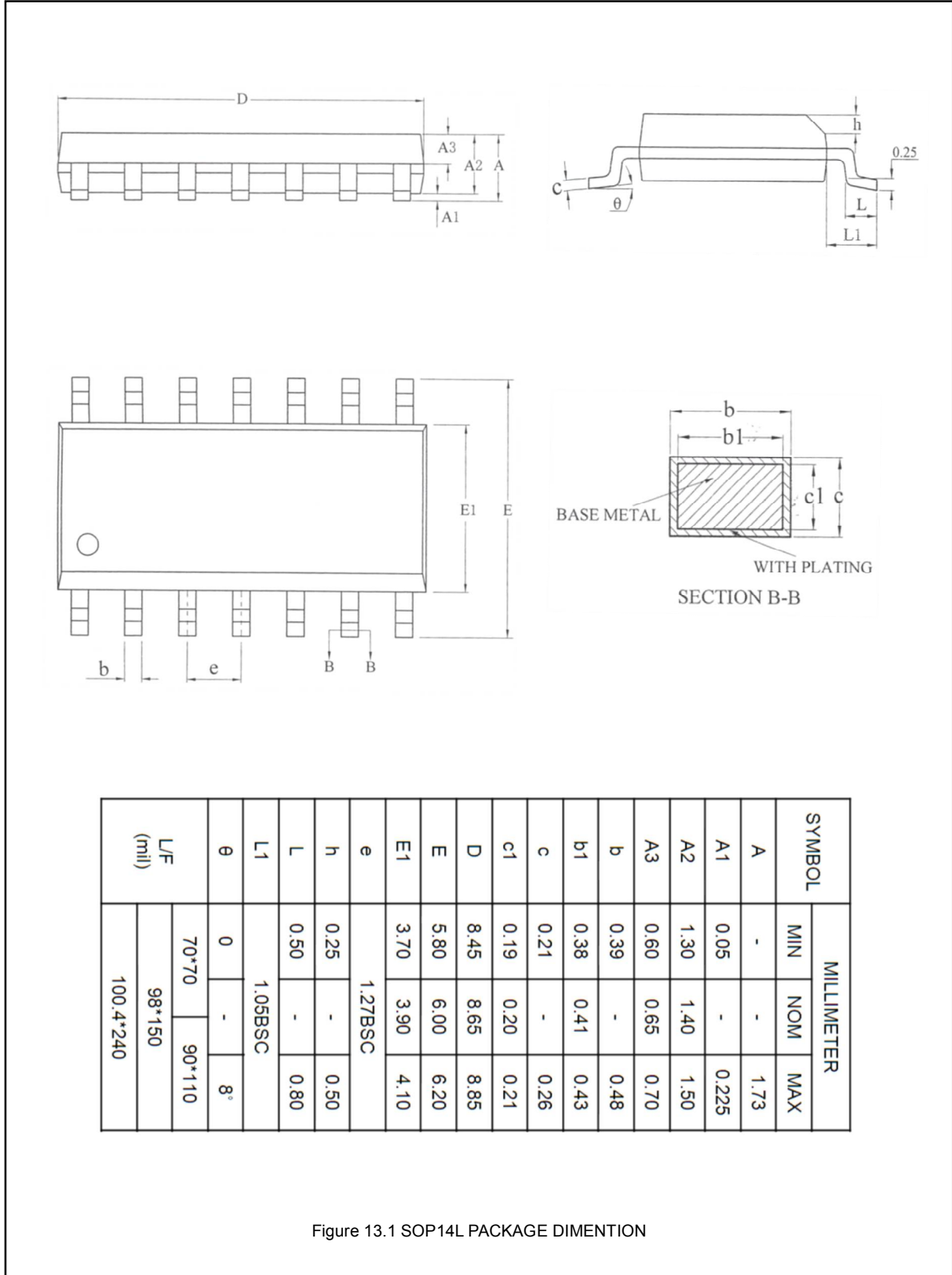

Figure 13.1 SOP14L PACKAGE DIMENTION

## 13-2. QFN16L PACKAGE

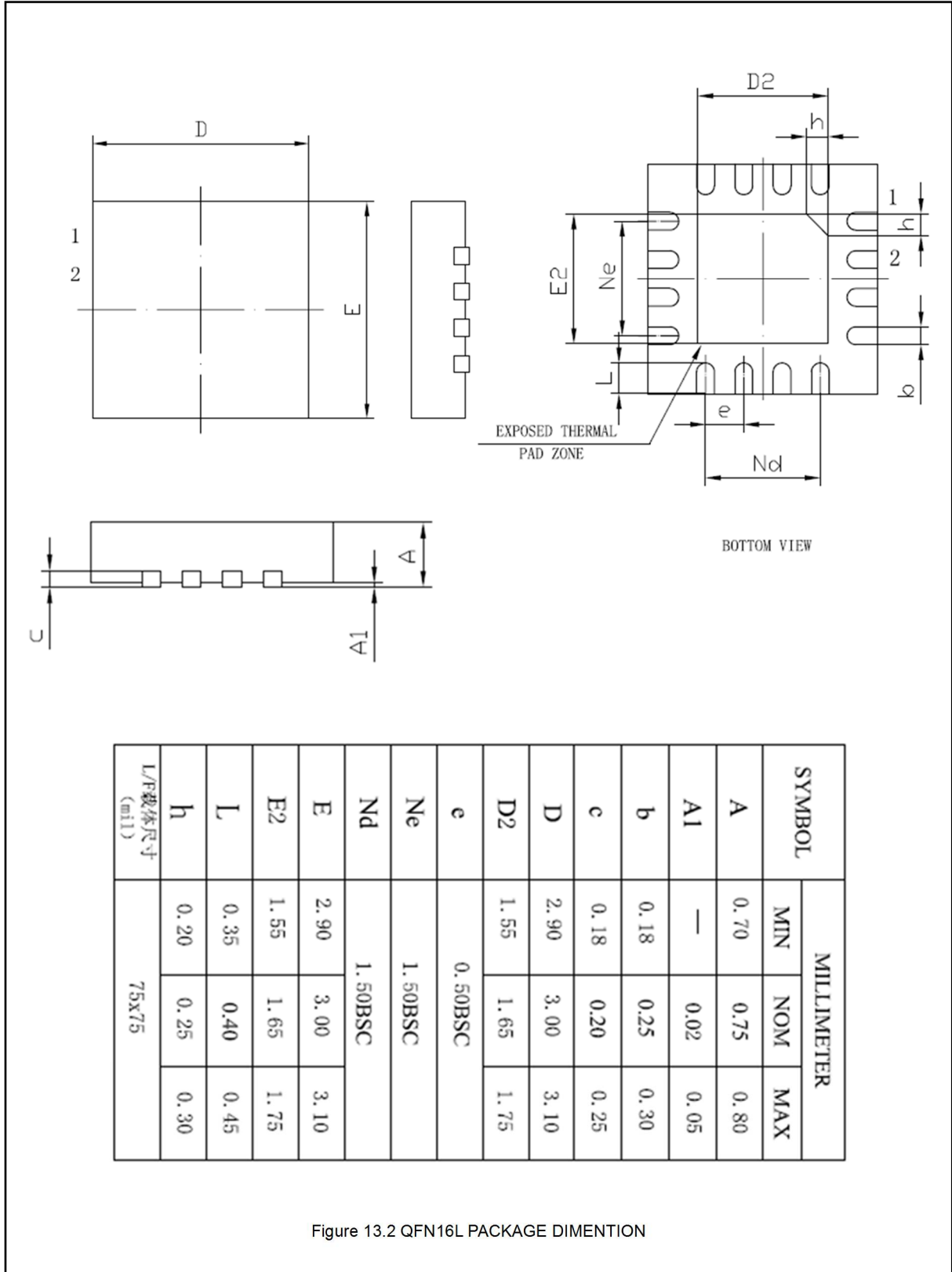

Figure 13.2 QFN16L PACKAGE DIMENTION