

The Classic of Touch Solution!

GREENCHIP

**GreenTouch3™ GT301L
Capacitive Touch Sensor**

**DATASHEET
VER2.20**

www.greenchip.co.kr

Important Notice

COPYRIGHT © 2009 BY GREENCHIP INC. - ALL RIGHTS RESERVED.

GREENCHIP OWNS ALL RIGHT, TITLE AND INTEREST IN THE PROPERTY AND PRODUCTS DESCRIBED HEREIN, UNLESS OTHERWISE INDICATED. NO PART OF THIS DOCUMENT MAY BE TRANSLATED TO ANOTHER LANGUAGE OR PRODUCED OR TRANSMITTED IN ANY FORM OR BY ANY INFORMATION STORAGE AND RETRIEVAL SYSTEM WITHOUT WRITTEN PERMISSION FROM GREENCHIP.

GREENCHIP RESERVES THE RIGHT TO CHANGE PRODUCTS AND SPECIFICATIONS WITHOUT WRITTEN NOTICE. CUSTOMERS ARE ADVISED TO OBTAIN THE LATEST VERSIONS OF ANY PRODUCT SPECIFICATIONS.

GREENCHIP MAKES NO WARRANTIES, EXPRESSED OR IMPLIED, OF MERCHANTABILITY OR FITNESS FOR A PARTICULAR PURPOSE, OTHER THAN COMPLIANCE WITH THE APPLICABLE GREENCHIP SPECIFICATION SHEET FOR THE PRODUCT AT THE TIME OF DELIVERY. IN NO EVENT SHALL GREENCHIP BE LIABLE FOR ANY INDIRECT, INCIDENTAL OR CONSEQUENTIAL DAMAGES AS A RESULT OF THE PRODUCT'S PERFORMANCE OR FAILURE TO MEET ANY ASPECT OF SUCH SPECIFICATION.

GREENCHIP PRODUCTS ARE NOT DESIGNED OR INTENDED FOR USE IN LIFE SUPPORT APPLIANCES, DEVICES OR SYSTEMS WHERE A MALFUNCTION OF A GREENCHIP DEVICE COULD RESULT IN A PERSONAL INJURY OR LOSS OF LIFE. CUSTOMERS USING OR SELLING GREENCHIP DEVICES FOR USE IN SUCH APPLICATIONS DO SO AT THEIR OWN RISK AND AGREE TO FULLY INDEMNIFY GREENCHIP FOR ANY DAMAGES RESULTING FROM SUCH IMPROPER USE OR SALE.

INFORMATION CONTAINED HEREIN IS PRESENTED ONLY AS A GUIDE FOR THE APPLICATIONS OF OUR PRODUCTS. GREENCHIP DOES NOT WARRANT THIS PRODUCT TO BE FREE OF CLAIMS OF PATENT INFRINGEMENT BY ANY THIRD PARTY AND DISCLAIMS ANY WARRANTY OR INDEMNIFICATION AGAINST PATENT INFRINGEMENT. NO RESPONSIBILITY IS ASSUMED BY GREENCHIP FOR ANY PATENT INFRINGEMENT RESULTING FROM USE OF ITS PRODUCTS BY THEMSELVES OR IN COMBINATION WITH ANY OTHER PRODUCTS. NO LICENSE IS HEREBY GRANTED BY IMPLICATION OR OTHERWISE UNDER ANY PATENT OR PATENT RIGHTS OF GREENCHIP.

THE GREENCHIP LOGO IS A REGISTERED TRADEMARK OF GREENCHIP.
THE GreenTouch3™ IS A REGISTERED TRADEMARK OF GREENCHIP.

www.greenchip.co.kr

Table of Contents

1. INTRODUCTION	5
2. FEATURES	5
3. BLOCK DIAGRAM	5
4. APPLICATIONS	5
5. ORDERING INFORMATION	5
6. MARKING INFORMATION	5
7. PIN DESCRIPTION	6
7.1 SOT23-6L PACKAGE	6
7.1.1 PACKAGE INFORMATION	6
7.1.2 PIN CONFIGURATION	6
7.2 DFN-6L PACKAGE	7
7.2.1 PACKAGE INFORMATION	7
7.2.2 PIN CONFIGURATION	7
8. FUNCTION DESCRIPTION	8
8.1 INTERNAL RESET	8
8.2 IMPLEMENTATION FOR TOUCH SENSING (SIN, RIN)	9
8.3 OUTPUT INTERFACE (OUT)	11
8.4 CTRL OPTION SELECTION (CTRL)	12
9. ELECTRICAL CHARACTERISTICS	13
9.1 ABSOLUTE MAXIMUM RATINGS	13
9.2 I/O ELECTRICAL CHARACTERISTICS	14
9.3 RESET CHARACTERISTICS	15
9.4 SENSING INPUT CHARACTERISTICS	15
9.5 SYSTEM CHARACTERISTICS	15
9.6 ESD CHARACTERISTICS	16
9.7 LATCH-UP CHARACTERISTICS	16
10. APPLICATION	17
10.1 EXAMPLE CIRCUIT	17

10.1.1 SOT23-6L PACKAGE	17
10.1.2 DFN-6L PACKAGE	17
10.2 APPLICATION NOTES	18
11. PACKAGE DIMENSION	20
11.1 SOT23-6L PACKAGE	20
11.2 DFN-6L PACKAGE	21

1. INTRODUCTION

The GT301L is one of GreenTouch3™ capacitive touch sensor series. Especially the GT301L can do capacitance sensing under GreenTouch3™ engine operation. GreenTouch3™ engine is an environmental compensation circuit.

Thanks to GreenTouch3™ engine, the application will be more robust and problem free against EMC, EMI, H/W variation, voltage disturbance, temperature drift, humidity drift and so on.

The GT301L offers whole solutions for 1-ch touch key applications, such as, normal mechanical switch replacements, liquid level sensor, and so on. Simple and easy application circuit can be also obtained by using GT301L because of its fundamental algorithms and pin maps. The GT301L has not only digital touch decision procedure that makes very reliable sensing determination but also smart algorithms that make it possible to detect slow action touch (In case of other touch sensor slow action touch is generally compensated). The GT301L has single touch sensing input pin and reference input pin to detect and determine capacitive touch, and single direct output pin which has open drain structure and operates as active low or toggle output function. Three connection types of CTRL pin make it possible to select two sensitivity options and toggle output function.

2. FEATURES

- 1 channel cap. Sensing input
- Embedded GreenTouch3™ Engine
 - Analog noise compensation circuit
 - Embedded digital noise filter
 - Intelligent sensitivity calibration
 - Embedded CS, EFT enhancer core
- Direct interface mode
 - Open drain and active low function
- Toggle output mode
 - It is possible by CTRL pin OPEN
- Low power consumption
 - NP - Standby mode: 65uA (@5.0V), 53uA (@3.0V)
 - LP - Standby mode: 27uA (@5.0V), 16uA (@3.0V)
- 1.8V to 5.5V single supply operation
- Mini package type
 - SOT23-6L
 - DFN-6L, 2x2
- RoHS compliant

3. BLOCK DIAGRAM

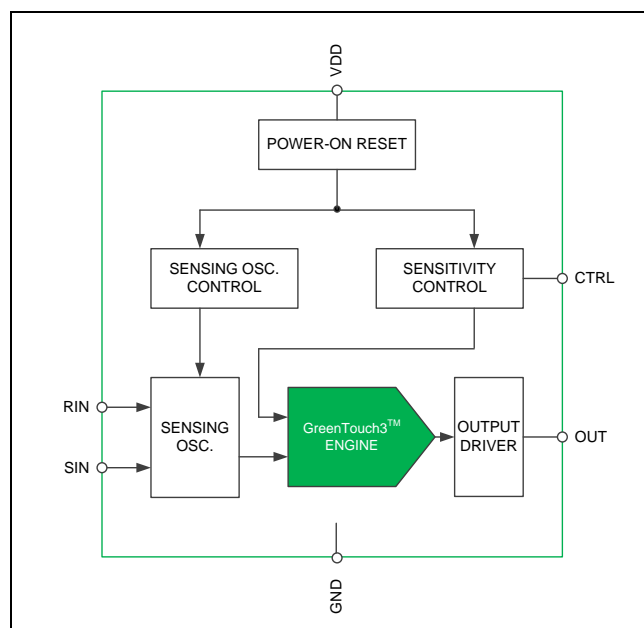

4. APPLICATIONS

- Multi key application - Door lock, Remote controller and Etc.
- Portable Electronics - Mobile phone, MP3, PMP, PDA, Navigation, Digital Camera, Video Camera and Etc.
- Multimedia Devices - TV, DVD player, Blue ray player, Digital photo frame, Home theater system and Etc.
- Home Appliance - Refrigerator, Air cleaner, Air conditioner, Washing machine, Micro wave oven and Etc.
- PC, OA and Others - PC, LCD monitor Fax, Copy machine, Lighting controls, Toys, Gaming devices and Etc.

5. ORDERING INFORMATION

Part No.	Package
GT301L-ST	SOT23-6L
GT301L-DN	DFN-6L, 2x2

6. MARKING INFORMATION

GYWW

- G: Device Code
- YY: Year Code (ex> 16:2016, 17:2017)
- WW: Week Code

7. PIN DESCRIPTION

This section describes the pin names and pin functions of GT301L. Pinout configuration also illustrated as below. The GT301L device is available in the following packages.

7.1 SOT23-6L PACKAGE

7.1.1 PACKAGE INFORMATION

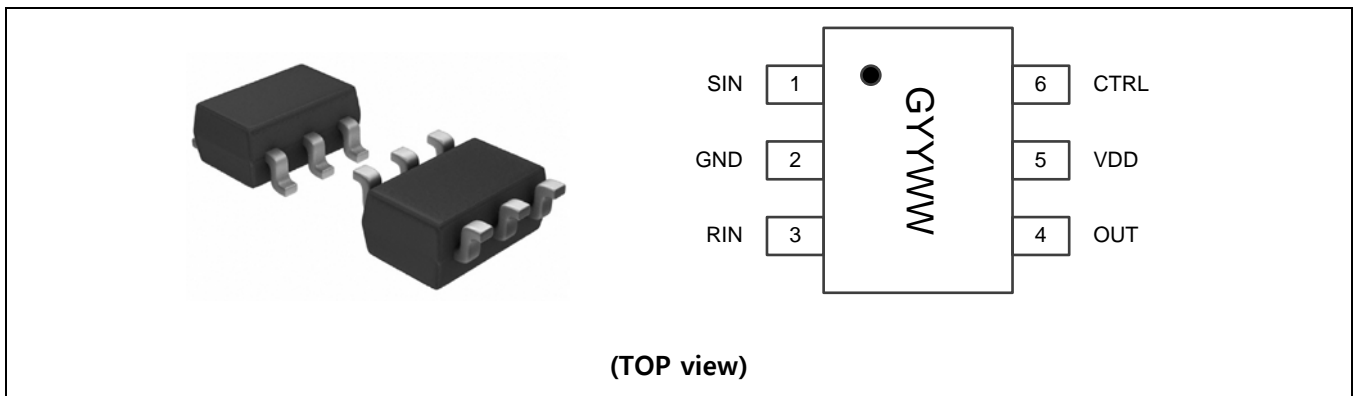

7.1.2 PIN CONFIGURATION

No.	Name	Type	Description
1	SIN	AI	Touch sensing input
2	GND	GND	Ground connection
3	RIN	AI	Capacitance reference input
4	OUT	DO	Direct Output for Touch Detection (Open Drain)
5	VDD	PWR	Supply Voltage
6	CTRL	DI	CTRL Option Selection Input - Connection to VDD : Low Power, Level Output, Sensitivity=12h - OPEN : Normal, Toggle Output, Sensitivity=0Ch - Connection to GND : Normal, Level Output, Sensitivity=0Ch

NOTE: DI: Digital Input, DO: Digital Output, DIO: Digital Input and Output, AI: Analog Input, AO: Analog Output, PWR: POWER

7.2 DFN-6L PACKAGE

7.2.1 PACKAGE INFORMATION

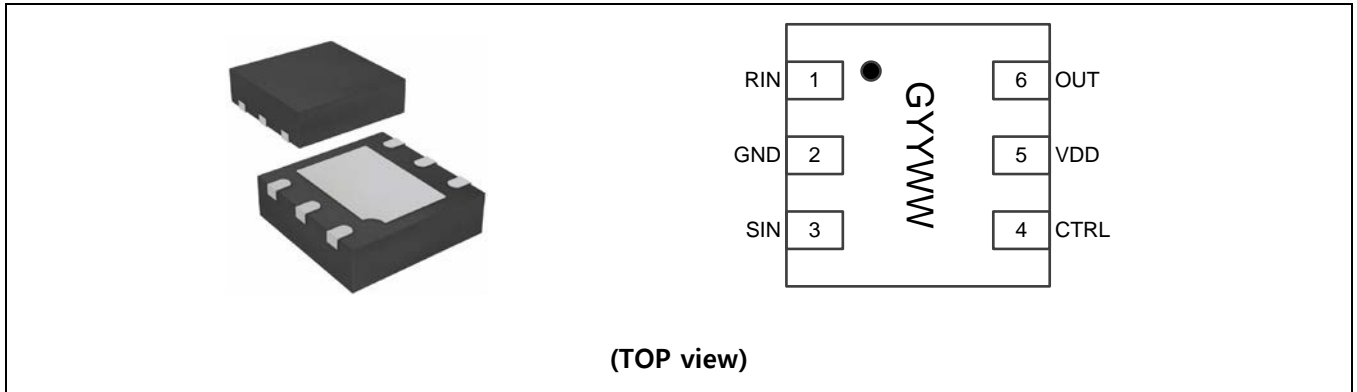

7.2.2 PIN CONFIGURATION

No.	Name	Type	Description
1	RIN	AI	Capacitance reference input
2	GND	GND	Ground connection
3	SIN	AI	Touch sensing input
4	CTRL	DI	CTRL Option Selection Input - Connection to VDD : Low Power, Level Output, Sensitivity=12h - OPEN : Normal, Toggle Output, Sensitivity=0Ch - Connection to GND : Normal, Level Output, Sensitivity=0Ch
5	VDD	PWR	Supply Voltage
6	OUT	DO	Direct Output for Touch Detection (Open Drain)

NOTE: DI: Digital Input, DO: Digital Output, DIO: Digital Input and Output, AI: Analog Input, AO: Analog Output, PWR: POWER

8. FUNCTION DESCRIPTION

8.1 INTERNAL RESET

The GT301L has internal power reset functions. The internal reset operation is used for initial power reset.

The internal power reset sequence is represented as below.

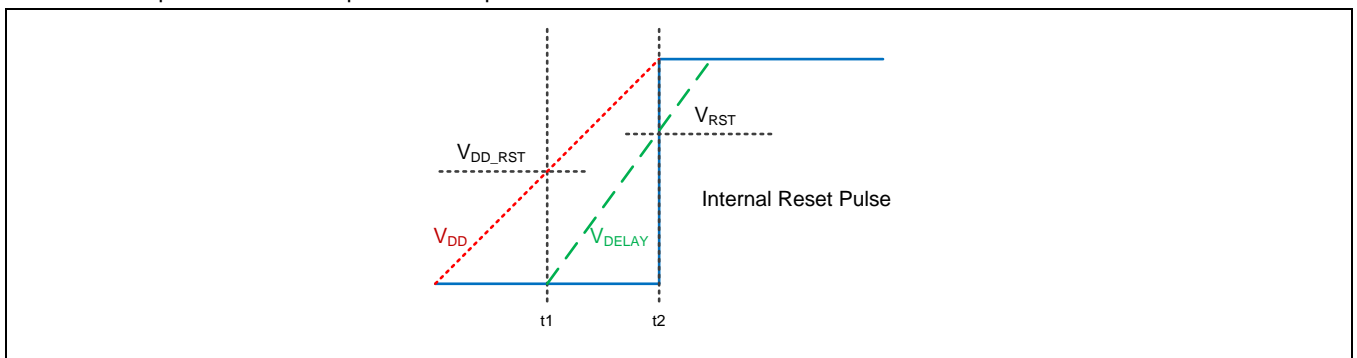

The internal V_{DELAY} voltage starts to rise when V_{DD} come up to V_{DD_RST} level. The internal reset pulse is maintained as low between t_1 and t_2 . During this low pulse period, the internal power reset operation is finished. Every time when V_{DD} drops under V_{DD_RST} internal reset block makes V_{DELAY} signal low and then internal reset pulse drops to low. By above internal reset operation sequence GT301L gets more certain and more correct power reset function than any others.

8.2 IMPLEMENTATION FOR TOUCH SENSING (SIN, RIN)

SIN input and RIN input are used for touch detection by capacitance variation sensing. The SIN input which is for direct touch sensing input is connected to touch sensing pad and catches capacitance variation caused by touching or approaching. The other RIN input which is for the reference capacitance measuring is connected only to a capacitor to compensate capacitance difference between SIN input and RIN input. The GT301L compares capacitance of SIN input and that of RIN input and makes touch detection output when capacitance of SIN input increases. So, for correct capacitance comparing both SIN input and RIN input, initial and steady state capacitance of both SIN input and RIN input is recommended approximately equal. Whenever SIN input has bigger capacitance than RIN input, the GT301L can make output signal of touch detection and output drive TR is activated to make OUT pin level "low". However in opposite case, in other words, when SIN input has much smaller capacitance than RIN input the GT301L cannot detect initial touch (Touch which is carried out from before power reset).

The GT301L also has various other intelligent sensing properties to detect correct touch free from error or sensitivity caused by various environmental noise effects. These advanced sensing methods will help faultless touch key systems under the worst conditions. Two sensitivity options of the GT301L are available and C_{SIN} capacitor is useful to adjust fine sensitivity reduction tuning, there will be no difficulty to satisfy systems require sensitivity. The internal intelligent sensitivity adjustment algorithm removes sensitivity rolling caused by system noise, circuit deviation, and circumstantial drift. The GT301L has a special noise elimination filter for more powerful noise rejection and it will be very helpful for proper touch operation even if the system environment becomes very deteriorative.

Implementation circuit for SIN input and RIN pin input is shown in figure below. The GT301L SIN input has an internal series resistor for ESD protection. Additional external series resistors are profitable for prevention of abnormal actions caused by radiation noise or electrical surge pulse. In any case, if the additional external series resistor (R_{EX_SIN}) of SIN input is required then it should be less than $1k\Omega$ and the location of resistor is recommended as closer to the SIN pins. Less $50pF$ capacitor can be used as C_{SIN} , C_{RIN} capacitor. Different from C_{RIN} , Both R_{EX_SIN} and C_{SIN} are not obligatory components.

The SIN input routing line for touch detection is desirable to be routed as short as possible and the width of routing path should be as narrow as possible and should be formed by bottom metal, in other words, an opposite metal of a touch PAD. The additional extension line pattern of RIN input on application PCB can help prevention of abnormal actions caused by radiation noise, but excessive long RIN input line can be a reason for failure of touch detect. The SIN input and RIN input lines for touch detection are desirable to be routed as far as possible from impedance varying path such as LED drive current path.

Implementation circuit for SIN pins and RIN pin is shown in the following figure.

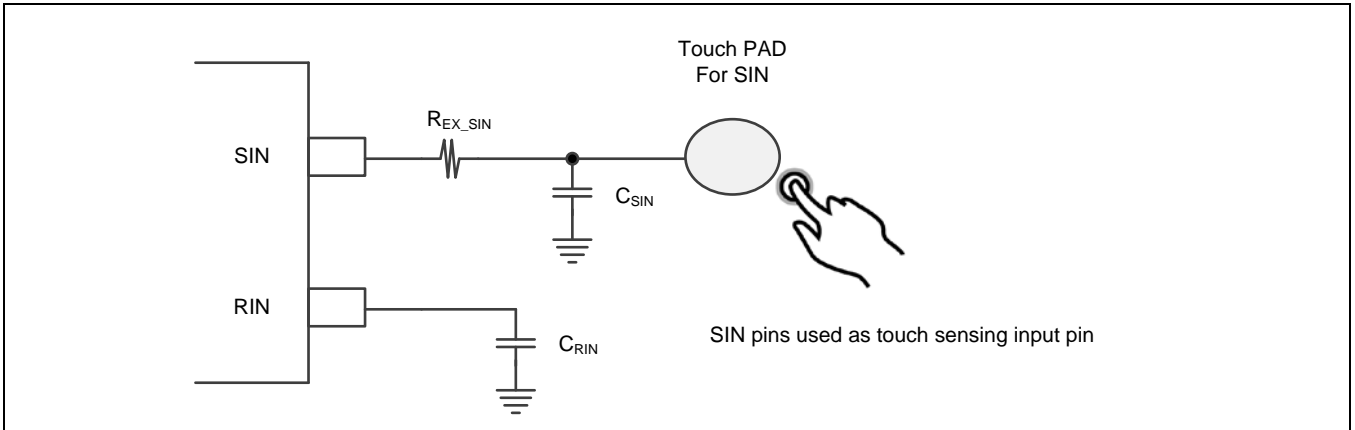

It is possible to control initial capacitance difference between SIN input and RIN input by using C_{RIN} capacitor according to C_{SIN} . For correct touch detection, initial and steady state capacitance of both SIN input and RIN input is recommended to be approximately equal. The procedure to reduce capacitance difference is expressed as below chart. Firstly, C_{SIN} capacitor must be determined considering proper sensitivity and then C_{RIN} capacitor value can be selected. If a too small C_{RIN} capacitor is used, the GT301L output has touch detection and output drive TR is activated to make OUT pin level "low". However in opposite case, in other words, when too big C_{RIN} capacitor is used the GT301L cannot detect initial touch.

8.3 OUTPUT INTERFACE (OUT)

The GT301L has OUT pin for direct output interface. The OUT pin has open drain NMOS structure and it needs pull-up resistors. Maximum output sink current of OUT pin is 8mA and a couple of k Ω can be used for these pull-up resistors (R_{OUT}). The implementation for OUT pin is shown in below figures.

The implementation for OUT pin is shown in the following figure.

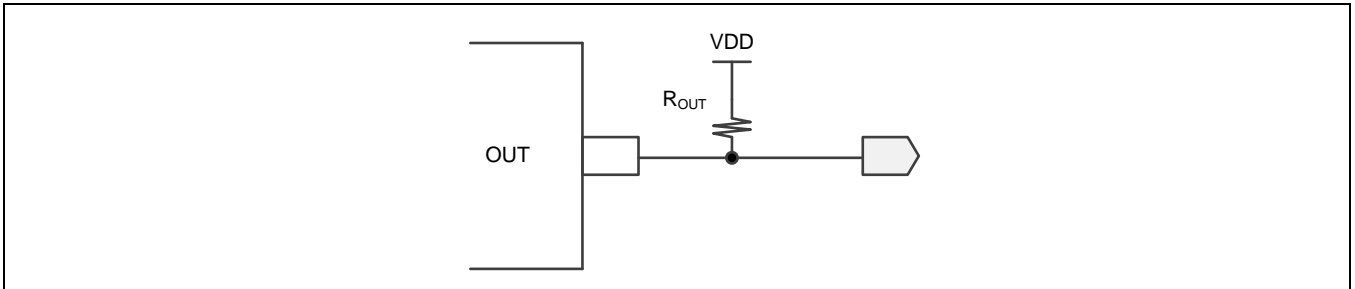

Toggle output mode is useful at lighting system on/off key switch application. For instance first touch can make light on output signal via OUT pin of the GT301L and this output signal maintains same light on states until next touch occurs.

The OUT waveform for each of output mode is shown in the following figure.

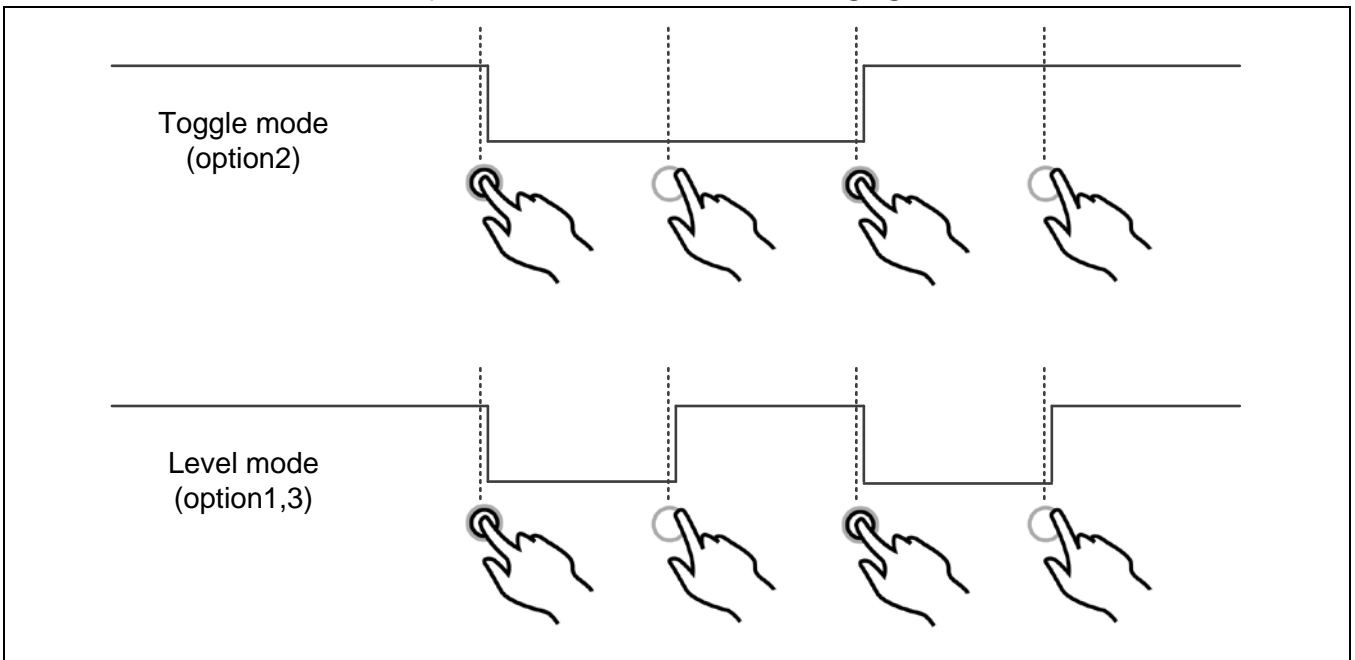

8.4 CTRL OPTION SELECTION (CTRL)

In the GT301L, three options are available by CTRL pin connection. Each option and its connections are shown in the table and figures below. This CTRL pulse signal starts at internal power reset time and finishes after a few operation period and options setting. For more detail sensitivity adjustment, CSIN capacitors should be used.

Each options and respective connection are shown in the following table.

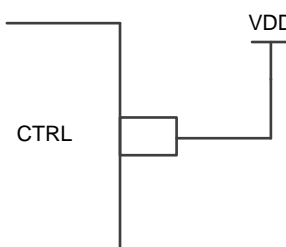
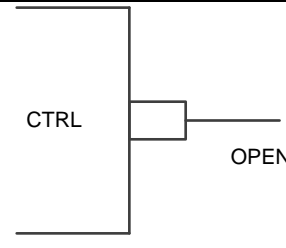
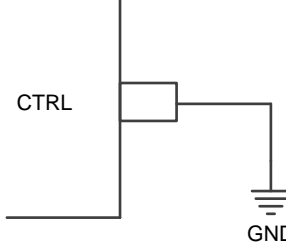
CTRL Option	Low Power (LP) Mode	Output Mode	Idle Time	Sensitivity
 <p>Option 1 (Connect to VDD)</p>	Enable LP (Low Power)	Level	230ms (@5.0V) 150ms (@3.0V)	12h
 <p>Option 2 (OPEN)</p>	Disable NP (Normal Power)	Toggle	35ms (@5.0V) 24ms (@3.0V)	0Ch
 <p>Option 3 (Connect to GND)</p>	Disable NP (Normal Power)	Level	35ms (@5.0V) 24ms (@3.0V)	0Ch

9. ELECTRICAL CHARACTERISTICS

9.1 ABSOLUTE MAXIMUM RATINGS

Parameter	Symbol	Conditions	Min	Typ.	Max	Units
Maximum supply voltage	V_{DD_MAX}		-0.3		6.0	V
Supply voltage range ⁽¹⁾	V_{DD_RNG}		-0.3		6.0	V
Voltage on any input pin	V_{IN_MAX}		-0.3		VDD +0.3	V
Maximum current into any pin	I_{MIO}		-100		100	mA
Power dissipation	P_{MAX}		-		800	mW
Storage temperature	T_{STG}		-65		150	°C
Operating humidity	H_{OP}	8 hours	5		95	%
Operating temperature	T_{OPR}		-40		85	°C
Junction temperature	T_J		-40		125	°C

NOTE: (1) This is the real valid power supply voltage range considering allowable supply tolerance. It cannot be used as target supply voltage range which is separately presented at below ELECTRICAL CHARACTERISTICS.

9.2 I/O ELECTRICAL CHARACTERISTICS

This section includes information about power supply requirements and I/O pin characteristics.

(TA = -25 to 85°C, V_{DD} = 1.8V to 5.5V)

Parameter	Symbol	Conditions	Min.	Typ.	Max.	Unit
Target supply voltage	V _{DD}		1.8	3.0 / 5.0	5.5	V
Current consumption	I _{DD1}	NP - Standby mode (VDD = 5.0V)	-	65	-	uA
		NP - Standby mode (VDD = 3.0V)	-	53	-	uA
	I _{DD2}	LP - Standby mode (VDD = 5.0V)	-	27	-	uA
		LP - Standby mode (VDD = 3.0V)	-	16	-	uA
Input high voltage	V _{IH}	All input pins	0.7VDD	-	VDD + 0.3	V
Input low voltage	V _{IL}	All input pins	-0.3	-	0.3VDD	V
Output low voltage	V _{OL}	All output pins (I _{OL} = 8mA, VDD = 5.0V)	-	-	0.4	V
Output sink current ⁽¹⁾	I _{SINK}	All output pins ⁽²⁾ (Active low)	-	-	8	mA
Output high leakage current	I _{LOH}		-	-	1	uA

NOTE:

(1) Test condition: VDD = 5.0V, TA = 25°C and normal operation mode under default control register value. (Unless otherwise noted)

(2) The OUT pin can be selected as open-drain NMOS structure (Active Low).

9.3 RESET CHARACTERISTICS

(TA = -25 to 85°C, V_{DD} = 1.8V to 5.5V)

Parameter	Symbol	Conditions	Min.	Typ.	Max.	Unit
POR ⁽¹⁾ Time	t _{POR}		-	-	600	usec

NOTE: (1) POR = Internal power-on reset

9.4 SENSING INPUT CHARACTERISTICS

(TA = -25 to 85°C, V_{DD} = 1.8V to 5.5V)

Parameter	Symbol	Conditions	Min.	Typ.	Max.	Unit
Minimum detectable input capacitance variant	ΔC _{S_MIN}		0.1	-	-	pF
Maximum input external capacitance	C _{EXT_MAX}		-	-	100	pF
Sense OSC internal series resistor	R _{INT}		-	140	-	Ω
external series resistor	R _{EXT_SIN}		-	200	1,000	Ω

9.5 SYSTEM CHARACTERISTICS

(TA = -25 to 85°C, V_{DD} = 1.8V to 5.5V)

Parameter	Symbol	Conditions	Min.	Typ.	Max.	Unit
Time for stable Touch Operating after Reset	t _{OP}		100	-	-	msec

9.6 ESD CHARACTERISTICS

Qualification tests are performed to ensure that these devices can withstand exposure to reasonable levels of static without suffering any permanent damage. During the device qualification, ESD stresses were performed for the Human Body Model (HBM), the Machine Model (MM) and the Charge Device Model (CDM).

Rating	Symbol	Value	Unit
Human body model (HBM)	V_{HBM}	± 8000	V
Machine model (MM)	V_{MM}	± 500	V
Charge device model (CDM)	V_{CDM}	± 2000	V

9.7 LATCH-UP CHARACTERISTICS

($T_A = 85^\circ\text{C}$)

Rating	Symbol	Value	Unit
Latch-up current	I_{LATCH}	± 200	mA

10. APPLICATION

10.1 EXAMPLE CIRCUIT

10.1.1 SOT23-6L PACKAGE

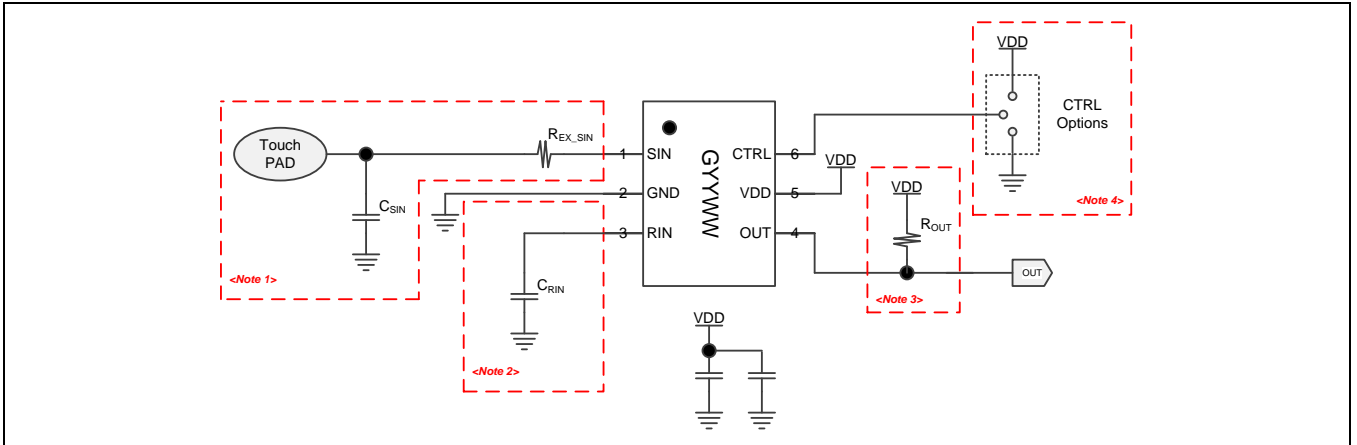

NOTE: $R_{EXT_SIN} = 200 \Omega$, $C_{SIN} = 1pF$, $C_{RIN} = 1pF$ (recommend)

10.1.2 DFN-6L PACKAGE

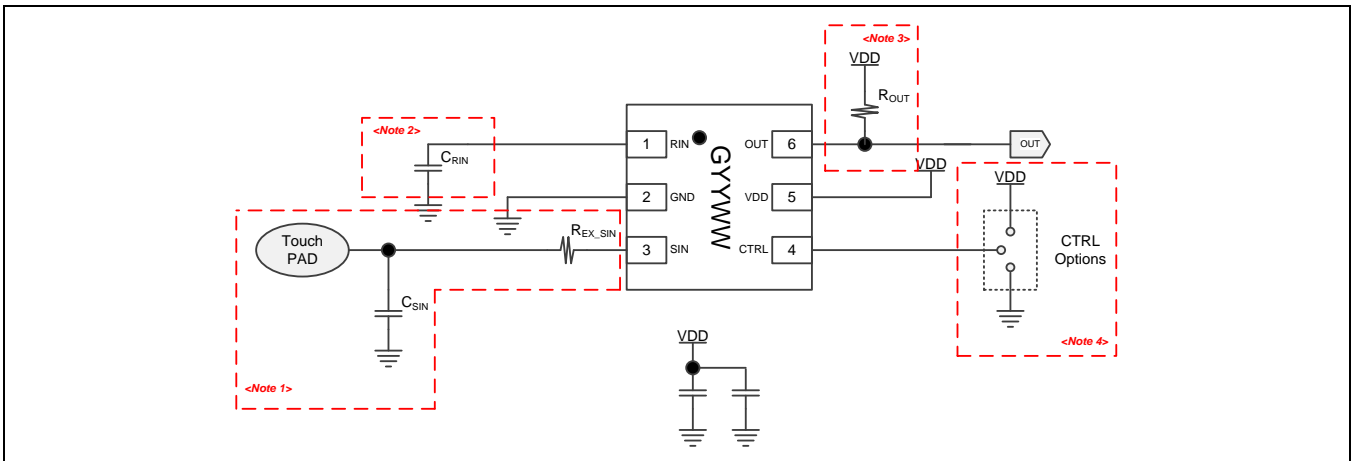

NOTE: $R_{EXT_SIN} = 200 \Omega$, $C_{SIN} = 1pF$, $C_{RIN} = 1pF$ (recommend)

10.2 APPLICATION NOTES

Normally a touch sensing operation is ultimately impedance variation sensing. Hence a touch sensing system is recommended to be taken care of prevention of the external sensing disturbance. Although the GT301L has enough noise rejection algorithms and various protection circuits to prevent noise causing error touch detection or incapable sensing, it is better to take care in noisy applications such as home appliances. There are many measurable or invisible noises in system that can affect the impedance sensing signal and distort that signal. The main principal design issues and required attentions are such as below.

- **Power Line**

- The touch sensor power line is recommended to be split from the other power lines such as relay circuits or LED that can make pulsation noise on their power lines.
- The big inductance that might exist in long power connection line can cause power fluctuation by other noise sources.
- The lower frequency periodic power noise such as a few Hz ~ kHz has more baneful influence on sensitivity calibration.
- An extra regulator for touch sensor is desirable for prevention above power line noises.
- The VDD under shooting pulse less than internal reset voltage (V_{DD_RST}) can cause system reset.
- The capacitor connected between VDD and GND is somehow obligation element for buffering above power line noises.

- **Sensing (Reference) Input Line for Touch Detect <Note1><Note2>**

- The SIN input line for touch detection is desirable to be routed as short as possible and the width of routing path should be as narrow as possible.
- The additional extension line pattern of RIN input on application PCB can help prevention of abnormal actions caused by radiation noise, but excessive long RIN input line can be a reason for failure of touch detect.
- The SIN input line for touch detection is recommended to be formed by bottom metal, in other words, an opposite metal of a touch PAD pattern.
- The SIN input and RIN input lines for touch detection are desirable to be routed as far as possible from impedance varying path such as LED drive current path.

It is possible to control initial capacitance difference between SIN input and RIN input by using C_{RIN} capacitor according to C_{SIN} . For correct touch detection, initial and steady state capacitance of both SIN input and RIN input is recommended approximately equal

- Additional external series resistors are profitable for prevention of abnormal actions caused by radiation noise or electrical surge pulse. The series resistor value should be less than 1k Ω and the location of resistor is better if it is closer to the SIN pins for better stable operation.

(Refer to IMPLEMENTATION FOR TOUCH SENSING)

- **Output Applications <Note3> <Note4>**

- OUT pins that is open drain NMOS TR type. Therefore a pull- resistor is required for a valid output. A couple of k Ω can be used for these pull-up resistors.

(Refer to OUTPUT INTERFACE)

- Toggle output mode can be realized by OPEN of CTRL pin.

(Refer to CTRL OPTION SELECTION)

11. PACKAGE DIMENSION

11.1 SOT23-6L PACKAGE

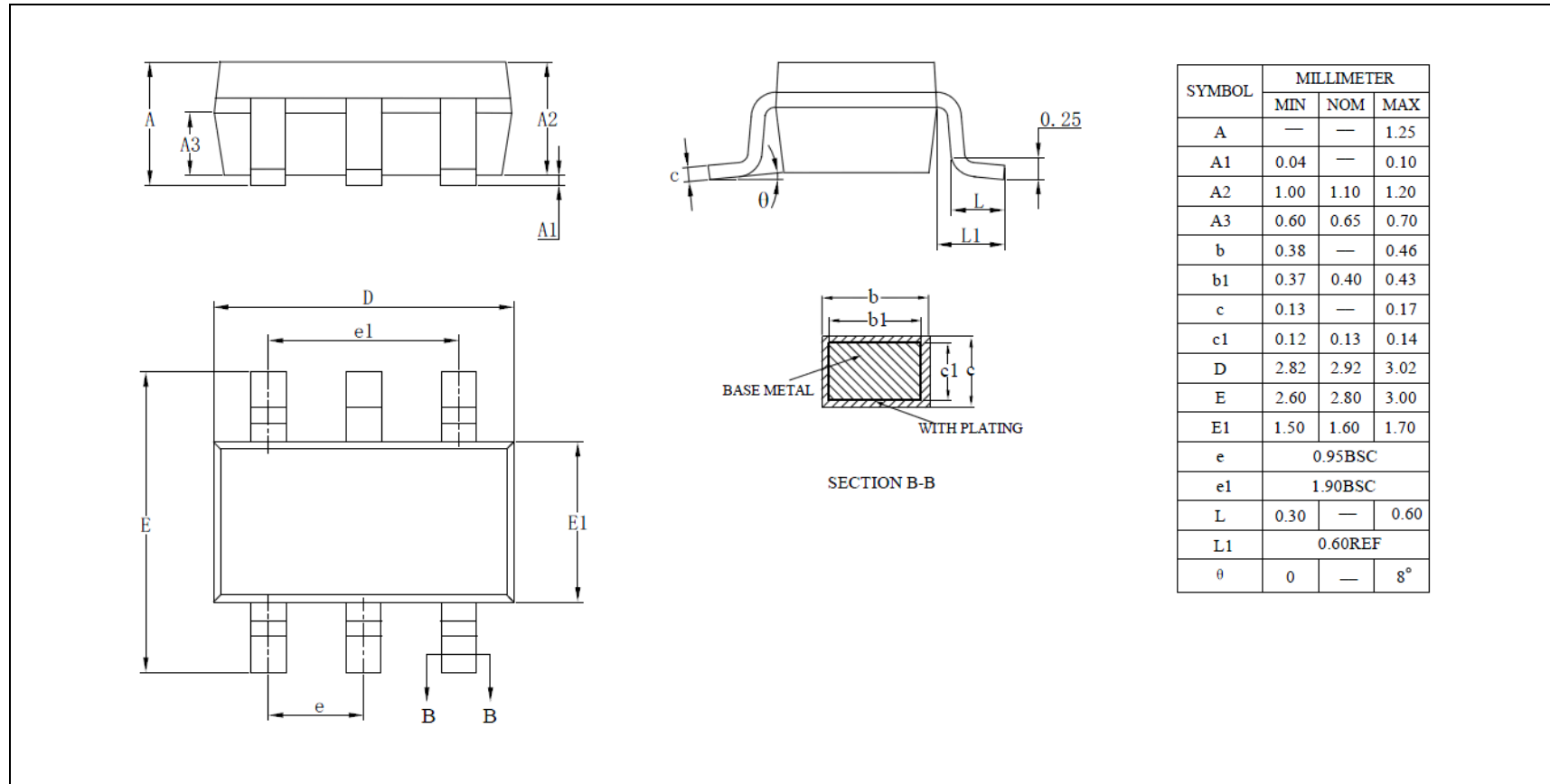

11.2 DFN-6L PACKAGE

