

Digital Universal Carbon Dioxide Sensor

DS-CO2-20 series data manual

Main characteristics

- ◆ NDIR
- ◆ Two Channels
- ◆ Industrial-grade Precision
- ◆ Minuscule Size



Overview

DS-CO2-20 is a kind of digital NDIR sensor, which can acquire and calculate the concentration of carbon dioxide in the air continuously and output them in the form of digital interface. This sensor can be inserted into variable instruments related to the concentration of carbon dioxide in the air or other environmental improvement equipments to provide correct concentration data in time.

Working principle

The sensor has one chamber and two receive channels that can get the signal of light intensity in the photoelectric element made by infrared light with two kinds of wavelength. Then the concentration of carbon dioxide can be calculated according to the carbon dioxide absorption function of the two kinds of wavelength.

Technical Index

Parameter	Index	unit
Effective Range	400~3000	ppm
Maximum Range	400~5000	ppm
Resolution	1	ppm
Maximum Consistency Error	± (50ppm+5%Reading)	
Single Response Time	<3	Second (s)
Total Response Time	≤25	Second (s)
Preheating Time	120	Second (s)
DC Power Supply	Typ:5.0 Min:4.5 Max: 5.5	Volt (V)
Active Current	400mA peak ,30mA average	Milliampere (mA)
Interface Level	L <0.8 @3.3 H >2.7@3.3	Volt (V)
Working Temperature Range	0~50	°C
Working Humidity Range	0~85% non condensed	
Storage Temperature Range	-40~+85	°C
MTTF	≥3	Year (Y)
Physical Size *	30×20×10	Millimeter (mm)
Pin Gap	2	Millimeter (mm)

Note 1: The physical size is not including the length of pin.

Pin Definition



Figure 1 Connector Definition

PIN1	VCC	Positive power 5V
PIN2	GND	Negative power
PIN3	SDA/TX	I2C SDA with drive mode of OD Serial port sending pin/TTL level@3.3V
PIN4	SCL/RX	I2C SCL with drive mode of OD Serial port receiving pin/TTL level@3.3V
PIN5	RESET	Module reset signal /TTL level@3.3V, low reset.
PIN6	SELECT	Interface Mode Select/TTL level@3.3V High or Float: Uart Low: I2C
PIN7	PWM	1Hz , 200us high level per 1PPM

Part Number Definition

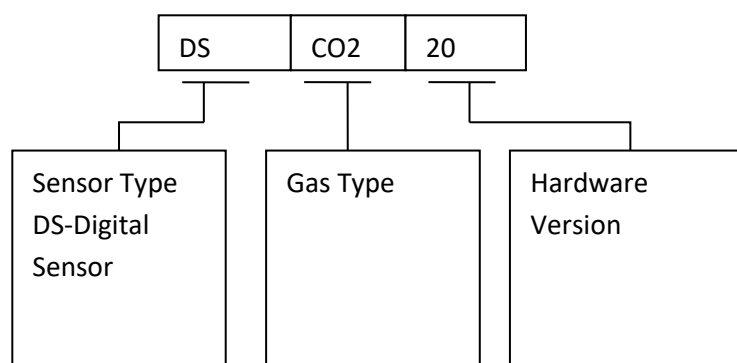

Physical Size(mm)

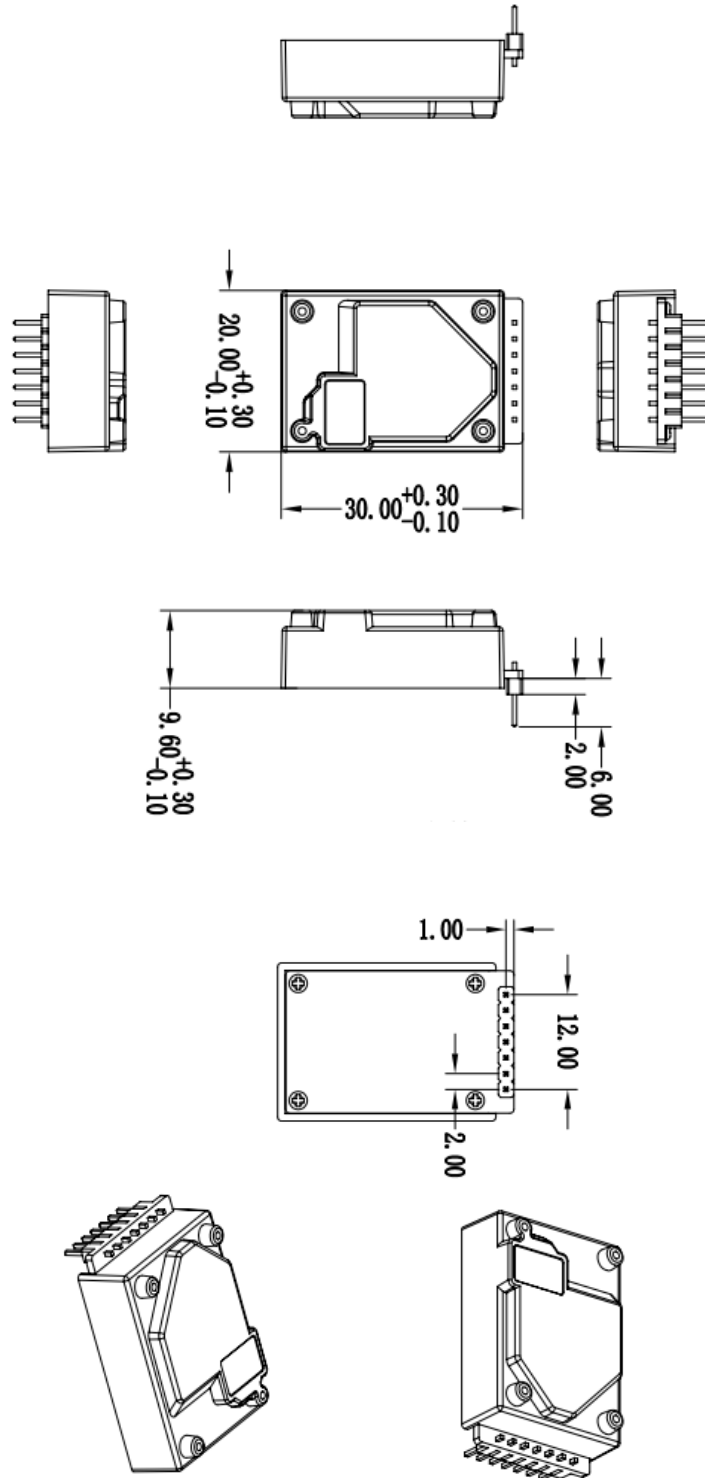

DS-CO2-20A

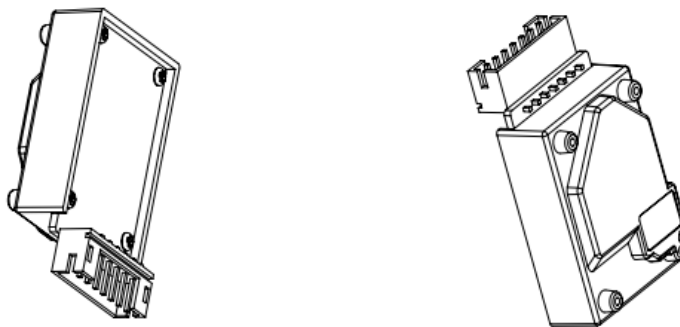
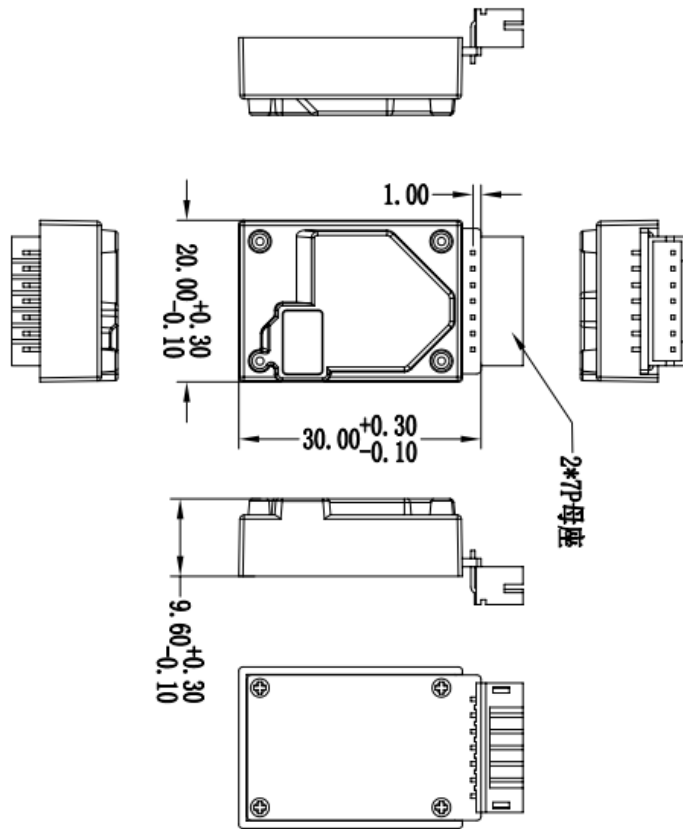

DS-CO2-20B

UART Interface

1. Base Definition

Default baud rate: 9600bps Check bit: None Stop bit: 1 bit

2. Protocol

2.1 host send

Start Byte1	StartByte2	Command	Para1	Para2	LRCH	LRCL
0x42	0x4d	0xe3	0x00	0x00	0x01	0x72

2.2 sensor feedback

Byte Number	Index	Value	
0x00	Start character 1	0x42(fixed)	
0x01	Start character2	0x4d(fixed)	
0x02	Frame length high	Frame length=2x3+2(data+check bytes)
0x03	Frame length low	
0x04	Data 1 high	CO2 ppm
0x05	Data 1 low	
0x06	Data2 high	Calibration Parameter1
0x07	Data2 low	
0x08	Data3 high	Calibration Parameter2
0x09	Data3 low	
0x0a	Check code high	Check code=Start character 1+ Start character 2++data 3 Low 8 bits *
0x0b	Check code low	

I2C Interface Protocol

1. Base Definition

1.1 Industry-standard NXP I2C bus interface

1.2 Data rate: 100ksp. Slave address(7 bit): 0x08

1.3 Sequence Diagram

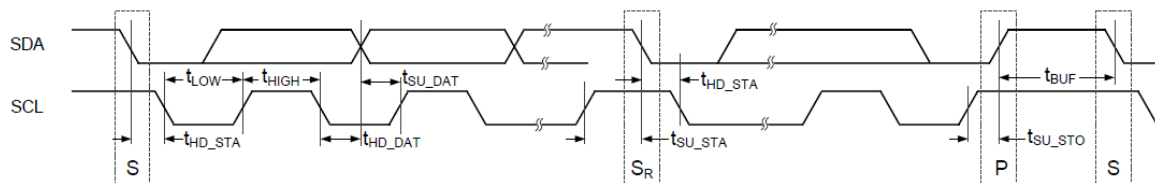

parameter	t_{HD_STA}	t_{LOW}	t_{HIGH}	t_{HD_DAT}	t_{SU_DAT}	t_{SU_STA}	t_{SU_STO}	t_{BUF}
Min	4.0	4.7	4.0	5.0	250	4.7	4.0	4.7
Unit	μs	μs	μs	μs	ns	μs	μs	μs

2. Operations

2.1 Master reads X bytes from slave buffer

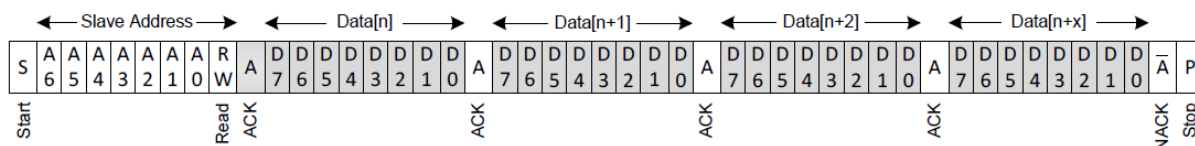

2.2 Master sets the base address and reads X bytes from slave buffer.

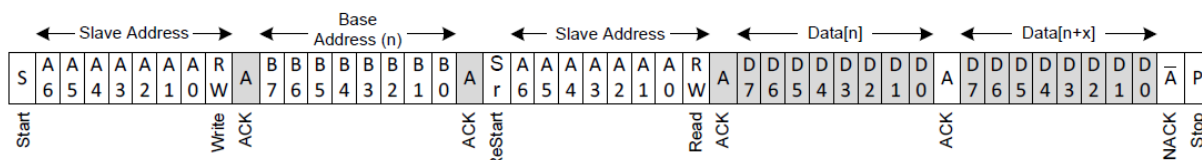

3. Registers Definition

Register Number	Index	Value
0x00	Start character 1	0x42(fixed)
0x01	Start character2	0x4d(fixed)
0x02	Frame length high
0x03	Frame length low
		Frame length=2x3+2(data+check bytes)

0x04	Data 1 high	CO2 ppm
0x05	Data 1 low	
0x06	Data2 high	Calibration Parameter1
0x07	Data2 low	
0x08	Data3 high	Calibration Parameter2
0x09	Data3 low	
0x0a	Check code high	Check code=Start character 1+ Start character 2+.....+data 3 Low 8 bits *
0x0b	Check code low	